



**Fisher  
Bioblock Scientific**

Parc d'innovation - BP 50111 - F67403 illkirch cedex

**France**

tél 03 88 67 14 14

fax 03 88 67 11 68

email [infos@bioblock.fr](mailto:infos@bioblock.fr)

[www.bioblock.com](http://www.bioblock.com)

**Belgique / België**

tél 056 260 260

fax 056 260 270

email [belgium@bioblock.com](mailto:belgium@bioblock.com)

[www.bioblock.be](http://www.bioblock.be)

**España**

tfno 91 515 92 34

fax 91 515 92 35

email [ventas@bioblock.com](mailto:ventas@bioblock.com)

[www.es.fishersci.com](http://www.es.fishersci.com)



# Operating Manual Freeze Dryer

## ALPHA 1-2 LDplus

Best.-Nr. 101521



**OPERATING MANUAL**  
**ALPHA 1- 2 LD<sub>plus</sub>**

Order Number:

Serial Number:

In case of inquiries please state the above numbers.

## Preface

Dear customer

Congratulations on purchasing a CHRIST freeze dryer.

The freeze dryer **ALPHA1-2 LD<sub>plus</sub>** is equipped with a lot of user-friendly options which make the operation easier for you.

The newly designed **ALPHA1-2 LD<sub>plus</sub>** is a universally usable CHRIST freeze dryer for laboratories, R&D departments and scientific institutes. Our well proven range of accessories allows application-oriented configuration of the equipment for almost all types of drying processes in round bottom flasks, dishes, ampoules, injection bottles, etc.

A special advantage is the easy-to-use and self-explaining unit operation with the new LD<sub>plus</sub> control system (Lyo-Display-plus):

Graphic LC display with a clear layout showing the most important process data (ice condenser temperature, process time, section time and vacuum)

- Comfortable and self-explaining menu guidance in German, English and French
- Conversion of product temperature and vacuum according to the vapour pressure curve for ice
- RS-232 communications interface (PC) available as an option
- Retrofitting of a vacuum control system using a pressure control valve and a vacuum sensor head (both available as accessories) possible

We can now offer you a freeze dryer combining functionality and convention utilisation.

We thank you for your confidence and wish you a successful application of your freeze dryer.

# Contents

<b>1.</b>	<b>General Information</b>	<b>1</b>
1.1.	Introduction .....	1
1.2.	Applications.....	2
1.3.	Technical Specifications of Freeze Dryer ALPHA 1-2 LD <sub>plus</sub> .....	3
1.4.	Standards and Regulations.....	6
1.5.	Safety Instructions .....	6
1.5.1.	CAUTION! Disconnect Mains Plug!.....	6
1.5.2.	CAUTION! Solvents!.....	6
1.5.3.	ADVICE! Cleaning and Maintenance of the Unit!.....	6
1.5.4.	WARNING! Freezing of Limbs to Surfaces! .....	6
1.5.5.	ADVICE! Transport Instructions! .....	7
1.6.	Prohibited Freeze Drying Processes .....	8
<b>2.</b>	<b>General Information on Freeze Drying</b>	<b>9</b>
2.1.	General Information on Freeze Drying.....	9
2.2.	Preparation .....	12
2.3.	Freezing .....	12
2.4.	Main Drying.....	13
2.5.	Final Drying.....	17
2.6.	End of Drying and Aeration.....	17
2.7.	Defrosting.....	18
<b>3.</b>	<b>Description of the Freeze Drying Processes</b>	<b>19</b>
3.1.	Separate Freezing and Drying Outside the Ice Condenser Chamber (Process B) on Shelves .....	19
3.2.	Separate Freezing and Drying Outside the Ice Condenser Chamber (Process B) with Sealing Device.....	20
3.3.	Separate Freezing and Drying of Liquids in Flasks (Process B).....	21
3.4.	Separate Freezing and Drying of Liquids in Ampoules (Process B) ..	22
<b>4.</b>	<b>Installation and Commissioning of the Unit</b>	<b>25</b>
4.1.	Site of Installation.....	25
4.2.	Mains Electricity .....	26
4.3.	Fuses on Site .....	26
4.4.	Checking the Earth Connection .....	26
4.5.	Aeration.....	26
4.6.	Condensate and Defrosting Water.....	26
4.7.	Vacuum Pump Exhaust .....	27
4.8.	Initial Start-up.....	27
4.8.1.	Functional Components and Control Elements.....	28

4.8.2.	Connection of Vacuum Pump and Installation of Accessory Components.....	29
4.8.3.	Switching-on .....	34
<b>5.</b>	<b>LDplus Control System</b>	<b>35</b>
5.1.	Introduction .....	35
5.2.	LDplus Control Panel .....	35
5.3.	Brief Guide - Handling.....	36
5.4.	Visual Components of the LDplus Control System .....	37
5.4.1.	Main window .....	37
5.4.2.	Status bar .....	37
5.4.3.	Softkey function .....	38
5.5.	Values Window .....	39
5.6.	Mode .....	40
5.6.1.	Starting a drying process.....	40
5.6.2.	Changing the phase .....	40
5.6.3.	Timer.....	41
5.7.	Main Menu .....	41
5.7.1.	Change set values.....	41
5.7.2.	Special functions .....	43
5.7.3.	Process and Equipment Information System .....	43
5.7.4.	Options .....	43
5.7.5.	Tutorial.....	45
5.8.	Process and Equipment Information System.....	45
5.8.1.	Information status .....	46
5.9.	LDplus Special Functions .....	46
5.9.1.	Defrost ice condenser (option) .....	46
5.9.2.	Electrical lifting device (option).....	47
<b>6.</b>	<b>Error Correction</b>	<b>49</b>
6.1.	Power Failure.....	49
6.2.	Insufficient Vacuum.....	49
6.3.	Unit does not function .....	51
6.4.	Insufficient Ice Condenser Temperature.....	51
6.5.	Process and Equipment Information System.....	52
6.5.1.	Error Messages .....	52
<b>7.</b>	<b>Maintenance</b>	<b>55</b>
7.1.	Ice Condenser Chamber.....	55
7.2.	Heat Exchanger .....	55
7.3.	Adjustment and Maintenance of the Vacuum Sensor VSP62.....	56
7.3.1.	Maintenance of the Vacuum Sensor: .....	56
7.3.2.	Replacement and adjustment.....	56
7.4.	Rubber Valves .....	57
7.5.	Vacuum Pump .....	58
7.6.	Exhaust Filter .....	58
7.7.	Cleaning.....	58
7.7.1.	Cleaning of the Freeze Dryer .....	58
7.7.2.	Cleaning of Accessories .....	59
7.7.3.	Maintenance of the Aeration Valve and the Drain Valve.....	59
7.7.4.	Disinfection of Drying Chamber, Lid and Accessories .....	59

7.7.5.	Checks by Operator.....	60
<b>8.</b>	<b>Options</b>	<b>61</b>
8.1.	Process Control System LPC-32, Software .....	61
8.2.	Process Control System LPC-32, Software with PC hardware.....	61
8.3.	LyoLog LL-1 (Documentation Software) .....	61
8.4.	LDplus Simulation Tool (Training Software) .....	61
<b>9.</b>	<b>Enclosures</b>	<b>63</b>
<b>10.</b>	<b>Special functions</b>	<b>79</b>



# 1. General Information

---

## 1.1. Introduction

### **What is freeze drying (Lyophilisation)?**

**Freeze drying means:** Extraction of water from frozen material. The drying process takes place by avoiding the liquid state through sublimation, i. e. direct conversion from ice to vapour. This happens under vacuum and the temperature in the product is normally less than -10°C.

**The aim of freeze drying** is to obtain an easily water soluble product which will have the same characteristics as the original product after addition of water.

As the drying process takes place in frozen state at very low temperatures it is possible to dry e. g. proteins which will not denature. Also most of the other chemical compounds will be qualitatively and quantitatively unchanged.

**Through freeze drying** the product, mainly of biological origin - such as tissues, tissue extracts, bacteria, vaccines and sera - is transformed into a dry product. During this process enzymatic, bacterial and chemical changes are largely avoided.

Freeze drying (lyophilisation) is the most gentle process for preserving the biological properties of sensitive tissue and tissue components.

Lyophilisation is also the best method when drying inorganic products – e.g. nanoscale dispersions – the particle surfaces of which should remain unchanged.



---

## 1.2. Applications

The freeze dryer **ALPHA 1-2 LD<sub>plus</sub>** is a high-performance universal laboratory and pre-production unit for freeze drying of solid or liquid products in ampoules, vials, glass flasks, plasma bottles or dishes. All operations necessary for freeze drying can be realized in one and the same unit:

- Freezing of the products (uncontrolled shelf surface temperature)<sup>1</sup>
- Freeze drying (sublimation) of the products at user-defined temperature limit values and pressure limit values
- Final drying of the products at user-defined temperature limit values and high final vacuum for the removal of capillary or molecularly bound water.

The freeze dryer **ALPHA 1-2 LD<sub>plus</sub>** is suitable for drying of e. g. bacteria and virus cultures, blood plasma, serum fractions, antibodies, sera, vaccines and pharmaceutical products such as chloramphenicol, streptomycin, vitamins, ferments as well as plant extracts for biochemical tests.

---

<sup>1</sup> Normally done separately in a deep-freeze

## 1.3. Technical Specifications of Freeze Dryer ALPHA 1-2 LD<sub>plus</sub>

	ALPHA 1-2 LD <sub>plus</sub>
<b>Performance data</b>	
Ice condenser capacity	max. 2.5kg
Ice condenser performance <sup>1)</sup>	max. 2kg/24h
Ice condenser temperature <sup>1)</sup>	approx. -55°C
Max. shelf surface area when drying outside the ice condenser chamber (process B):	3 shelves, Ø200 A <sub>total</sub> 0.092m <sup>2</sup> spacing: up to 80mm with accessory no. 120893
Max. shelf surface area when drying in glass vials with sealing under vacuum or nitrogen atmosphere outside the ice condenser chamber (process B):	2 shelves, Ø200 A <sub>total</sub> 0.054m <sup>2</sup> spacing: 25-70mm with accessory no. 121015
Drying in round bottom flasks. Please note that the max. ice condenser capacity is 2kg (process B):	8 pieces, with accessory no. 121450
<b>Physical data (without vacuum pump):</b>	
Dimensions of the unit:	width: 315mm height: 345mm depth: 460mm (incl. vacuum flange connection)
Weight:	approx. 28kg

	<b>ALPHA 1-2 LD<sub>plus</sub></b>
Noise emissions according to DIN 45635:	49 dB(A)
Electromagnetic compatibility according to EN 55011:	class B
<b>Filling quantities:</b>	
Refrigerant:	see label on the back of the unit
<b>Connection requirements with vacuum pump 0.4KVA:</b>	
Electrical connection:	230V / 50-60Hz (others upon request)
Power consumption:	1,2kVA
Max. current:	5A
Fuse protection:	6A
Ambient temperature:	Climate category: SN +10°C to +32°C (higher temperatures upon request)
<b>Equipment connections:</b>	
Vacuum connection:	Small flange connection DN 25 KF (ISO 28403, DIN 2861)

	<b>ALPHA 1-2 LD<sub>plus</sub></b>
Drain valve:	Hose nozzle DN10 (outside diameter 12mm)
Aeration valve:	Hose nozzle DN4 (outside diameter 8mm)

<sup>1)</sup> All machine specifications (especially for temperatures, power and capacity) refer to the nominal ambient temperature of 20°C

**The scope of delivery includes:**

- 1 tube of high-vacuum grease
- 1 litre vacuum pump oil (only in case a pump is delivered)
- 0.5 m drain hose (silicone 9 x 12 mm)
- 1 operating manual and further detailed technical documentation

**The scope of delivery does not include:**

- Commissioning of the unit (inside Germany) can be performed upon request and will be invoiced at cost.
- Installation of the exhaust pipe of the vacuum pump (not necessary when using an exhaust filter).

---

## 1.4. Standards and Regulations

Please refer to the enclosed EU Declaration of Conformity.

---

## 1.5. Safety Instructions

### 1.5.1. CAUTION! Disconnect Mains Plug!



As current-carrying parts are accessible inside the unit the mains plug must be disconnected before the side panels are opened or before the control panel is removed.

For maintenance work the unit must be switched off with the mains switch.

### 1.5.2. CAUTION! Solvents!



Acidic products or products with a high solvent concentration cannot be dried without special protective measures and devices such as e.g. a cooling trap for protection of the vacuum pump (if necessary check with our service department). Besides, the unit may be damaged by corrosion.

Special caution is necessary when using azides because a dangerous explosive develops in combination with copper or non-ferrous metals! It is absolutely essential to consult our service department!

### 1.5.3. ADVICE! Cleaning and Maintenance of the Unit!



For infectious, toxic, pathogenic and radioactive substances the corresponding safety regulations must be observed.

### 1.5.4. WARNING! Freezing of Limbs to Surfaces!



During operation of the freeze dryer dangerous situations in the ice condenser chamber may arise. When putting in the shelves take care that limbs do not come into contact with the condenser in

the ice condenser chamber as the limbs may become frozen to the surface. The limb can only be detached from the surface by applying heat. Liquid should not be used.

### 1.5.5. **ADVICE! Transport Instructions!**



Please keep the packaging for possible subsequent dispatch.

The freeze dryer should be carried by two persons by holding it underneath on both sides.

**WARNING!** When transporting or putting down the unit do not hold the plastic control panel. Please note: When putting the unit down on a surface there is a danger of squeezing hands or fingers.



**WRONG**



**CORRECT**

---

## 1.6. Prohibited Freeze Drying Processes

1. Operation of freeze dryer when not installed correctly.
2. Operation of freeze dryer without panels.
3. Operation of freeze dryer by non-authorized personnel.
4. Operation of freeze dryer with shelves not installed properly.
5. Operation of freeze dryer with very corrosive substances. It is not allowed to dry these substances, at least special safety measures have to be observed. The corrosive substances must not cause damage to material and must not degrade the mechanical strength of the ice condenser chamber, the drying chamber, the lid or the accessory components.
6. Operation of freeze dryer with accessories not allowed by the manufacturer, except for commercial freeze drying vessels made of glass or plastic. The user is explicitly warned not to use poor quality goods. Breaking glass or bursting vessels can cause dangerous situations during freeze drying.
7. Operation of freeze dryer in locations with danger of explosion.
8. During operation the freeze dryer must not be knocked or moved. Leaning against or resting on the freeze dryer is not allowed.
9. Do not place potentially dangerous material, e. g. glass vessels containing liquids, near the freeze dryer.
10. Products which could react to the supply of high energy during the freeze drying process must not be dried.
11. Do not freeze dry explosive or highly inflammable substances.
12. Infectious, toxic, pathogenic and radioactive substances must only be dried in suitable vessels.

# 2. General Information on Freeze Drying

---

## 2.1. General Information on Freeze Drying

Freeze drying is the most gentle process for drying products. It is based on the physical phenomenon of sublimation i.e. the direct conversion from solid to gaseous state. The frozen product is placed in the vacuum drying chamber for drying. The ice condenser can also be described as a vapour pump as the moisture which evaporates under vacuum during drying freezes onto the ice condenser. Consequently the vacuum pump is only intended to remove the air from the drying chamber (=gas pump) but not the vapour. In order to start the sublimation process, energy must be supplied to the product. This takes place during drying in round bottom flasks or wide-neck filter bottles etc. due to the much warmer environment (direct heat contact), on unheated shelves by means of heat radiation from the environment and directly by means of the shelves when heatable. Once the "free water" has been removed from the product, it is also possible to remove the marginally contained adsorptively bound water by means of very low vacuum. This part of the drying process is referred to as final drying (desorption).

The main components of a freeze dryer are :

Vacuum drying chamber with heating device

- a) heatable<sup>2</sup> and unheatable shelves for drying in dishes
- b) shelves with sealing device for drying in bottles
- c) rubber valves for connecting round bottom flasks, wide-neck filter bottles, etc.
- d) manifold for connecting round bottom flasks, wide-neck filter bottles, etc.

Pumps to evacuate air and water vapour

- a) vacuum pump to evacuate the drying chamber  
**(= gas pump)**

---

<sup>2</sup> Heatable (controlled) shelves are only possible with an LSC control system.



- b) ice condenser with temperatures from  $-50^{\circ}\text{C}$  to  $-105^{\circ}\text{C}$  (depending on type of unit) to remove the water vapour from the chamber  
(= vapour pump)

### Sublimation

The principle of sublimation is briefly explained using the phase diagram of water (freeze drying of mainly aqueous solutions, see vapour pressure curve). If the atmospheric pressure is higher than 6.11 mbar, water passes through all three phases (solid, liquid, gas) when the temperature is lowered or raised. At 6.11 mbar the melting pressure curve, vapour pressure curve and sublimation pressure curve meet in one point called triple point. At this point all three phases occur in parallel (simultaneously). Below this point, i.e. the pressure is lower than 6.11 mbar, the ice is converted directly from a solid to a gaseous phase on reaching the sublimation pressure curve (vapour pressure curve above ice).

### Vapour pressure curve for ice and water

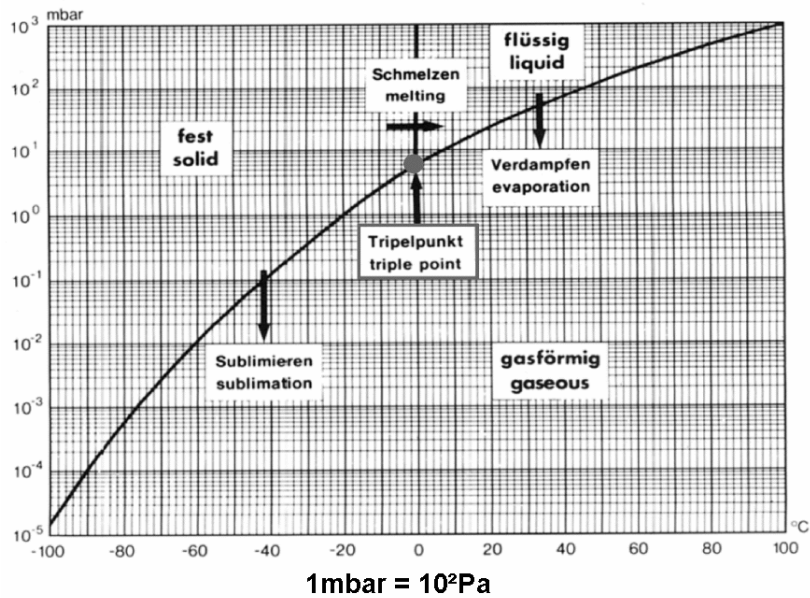

**Conversion table "Vapour pressure above ice"  
(sublimation curve) 1 mbar = 10<sup>2</sup> Pa = 1hPa**

°C	△ mbar	°C	△ mbar	°C	△ mbar	°C	△ mbar
0	6.110	-20	1.030	-40	0.120	-60	0.011
-1	5.620	-21	0.940	-41	0.110	-61	0.009
-2	5.170	-22	0.850	-42	0.100	-62	0.008
-3	4.760	-23	0.770	-43	0.090	-63	0.007
-4	4.370	-24	0.700	-44	0.080	-64	0.006
-5	4.020	-25	0.630	-45	0.070	-65	0.0054
-6	3.690	-26	0.570	-46	0.060	-66	0.0047
-7	3.380	-27	0.520	-47	0.055	-67	0.0041
-8	3.010	-28	0.470	-48	0.050	-68	0.0035
-9	2.840	-29	0.420	-49	0.045	-69	0.0030
-10	2.560	-30	0.370	-50	0.040	-70	0.0026
-11	2.380	-31	0.340	-51	0.035	-71	0.0023
-11	2.170	-32	0.310	-52	0.030	-72	0.0019
-13	1.980	-33	0.280	-53	0.025	-73	0.0017
-14	1.810	-34	0.250	-54	0.024	-74	0.0014
-15	1.650	-35	0.220	-55	0.021	-75	0.0012
-16	1.510	-36	0.200	-56	0.018	-76	0.0010
-17	1.370	-37	0.180	-57	0.016	-77	
-18	1.250	-38	0.160	-58	0.014	-78	
-19	1.140	-39	0.140	-59	0.012	-79	

**The process steps of freeze drying**

**Freezing**

Under atmospheric pressure  
(e. g. at -25°C)

= Formation of the ice structure

**Drying**

Under vacuum  
e. g. at 0,01 mbar

= Keeps the water contents in  
ice phase



**Additionally necessary**  
Energy input (= heat)

**but:** the material remains in the  
solid/ice phase

(Physical law: the vacuum is  
responsible for the product  
temperature)

---

## 2.2. Preparation

**In case the unit is equipped with a pressure control valve the vacuum pump should be warmed up.** The operation temperature should be reached before loading the vacuum pump with condensable gases. In this way, the service life of the vacuum pump can be considerably extended.

The vacuum pump can be operated already during the freezing process when the pressure control valve is closed. The vacuum pump should be warmed up for at least 15 minutes or it should be switched on at least 15 minutes before starting the main drying process.

It may occur that the vacuum in the ice condenser chamber or in the drying chamber goes up during the main drying process (e.g. from 0.63 mbar to 0.47 mbar) although the valve to the vacuum pump is closed. This can be explained physically by the pumping effect of the ice condenser ("Cryo Pumping Effect").

---

## 2.3. Freezing

Small product quantities are frozen directly inside the ice condenser chamber of the freeze dryer. Larger quantities are pre-frozen in a deep-freeze.

If liquids are to be dried in bottles with a layer thickness of more than 1 cm we recommend that pre-freezing is carried out with a shell or spin freezing device in a cooling bath (see picture). Due to the centrifugal force the liquid to be frozen will rise on the wall of the bottle and freeze. With this freezing process the layer thickness is reduced and thus the total drying period is shortened considerably.

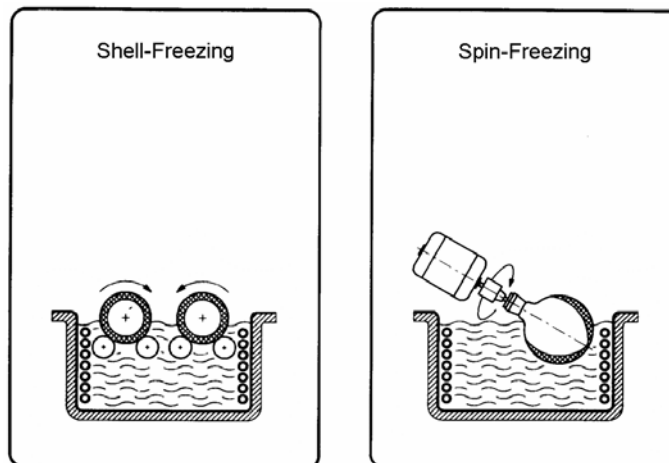



Freezing inside the unit is not necessary if the product is pre-frozen or stored in e. g. a deep-freeze. In this case, especially when freeze drying small quantities, it is advisable to pre-cool the shelves in order to avoid partial thawing during the evacuation.

Possible water residue must be removed from the ice condenser chamber. The drain valve is closed.

The ground-in stopper of the drying chamber must be greased with high-vacuum grease!

The layer thickness of the product should not exceed 1 to 2 cm as otherwise this has a negative effect on the duration of the drying process.

---

## 2.4. Main Drying

The vacuum pump is switched on.

**Please note:**

Defrosting during the drying process is possible (visible foaming) when drying products containing e. g. solvents or high salt concentrations. In this case it is necessary to freeze the product at temperatures as low as possible, e.g. in liquid nitrogen.

**Warning:**

Acidic products or products with a high solvent concentration cannot be dried without special safety measures and devices e.g. an additional LN<sub>2</sub> cooling trap for protection of the vacuum pump (if necessary contact our company). Another possibility is to use chemical resistant vacuum hybrid pumps (e.g. RC-5).



**Special precautions are necessary when using azides because a dangerous explosive develops in combination with copper or non-ferrous metals! It is absolutely essential to consult our company!**

As soon as sublimation of the water vapour from the frozen product begins, heat is extracted and consequently the product continues to cool down.

The maximum rate of sublimation is reached at the start of the drying process.

Depending on the rate of sublimation the ice condenser temperature and thus the pressure in the drying chamber respectively ice condenser chamber rises.

**The duration of the main drying phase depends mainly on:**

- the layer thickness of the product,
- the solid content of the product,
- the heat supplied to the product during the drying process,
- the pressure inside the drying chamber during the drying process.

With increasing pressure (not vacuum!) the rate of sublimation rises and the drying period is shortened.

The water vapour generated during the main drying phase is not pumped off by the vacuum pump but collected by the ice condenser.

The purpose of the vacuum pump is to lower the partial pressure of the non-condensable gases so that the water vapour can be transported from the product to the ice condenser.

However, small quantities of water vapour are also pumped off by the vacuum pump. Therefore, the vacuum pump is equipped with a gas ballast device.

If the gas ballast valve is open the extracted condensable vapours will be emitted via the exhaust pipe together with air.

**For this reason the gas ballast valve must be open during the main drying phase!**

The gas ballast valve can only be closed for final drying since there is not much water vapour left during this section of the drying process.

During the main drying phase the moisture is removed by sublimation, during final drying the bound moisture is removed by desorption.

This small quantity of water vapour generated during the final drying phase can be pumped off by the vacuum pump even when the gas ballast valve is closed (for some hours).

In general, operation with closed gas ballast valve is not necessary. The recommended vacuum pump reaches with open gas ballast valve a final pressure which corresponds to the water vapour partial pressure that can be reached.

**The residual moisture of the dried product depends mainly on:**

- the temperature of the dried product during the final drying process,
- the final vacuum reached during the final drying process.

The end of the main drying phase is reached, when the product temperature is nearly the same as the shelf temperature (temperature difference between shelf and product approx. 3 K to 5 K). If the adsorptively bound water is to be removed from the product, the final drying phase can be started.

The following picture shows the drying process for a product containing approx. 10 % solid matter. During the first quarter of the main drying phase 50 % of the water content is condensed. During the next quarter of the main drying phase 50 % of the remaining water content is condensed. This continues until the drying curve approaches the time axis asymptotically. This typical drying curve is due to the fact that the area of sublimation recedes into the product and the water vapour still to be extracted has to pass through the already dried layers. During the drying process the inner resistance increases. Thus the drying curve is primarily determined by the latent heat of sublimation and the water vapour transport speed. In order to increase the specific heat conduction properties of the product to be dried and to keep the water vapour volume as low as possible it is necessary that drying takes place as close as possible to the solidification point (eutectic point).

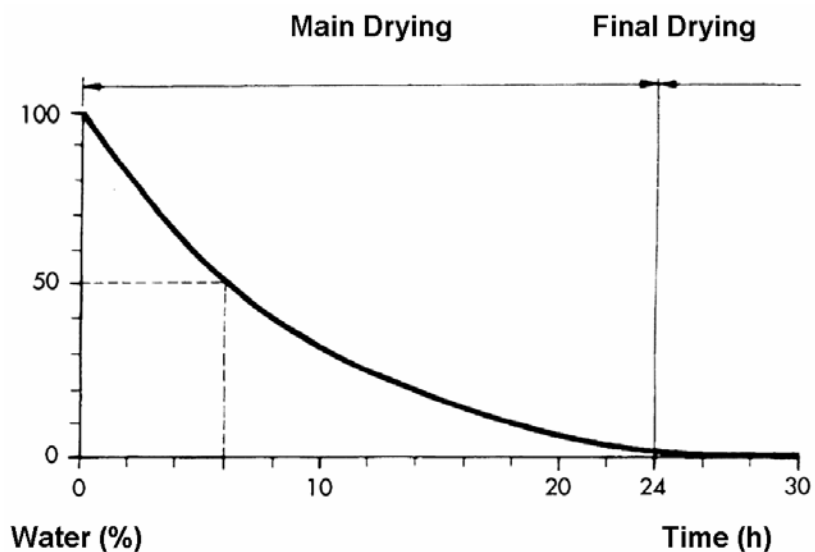

The drying time depends heavily on the drying vacuum. The nearer the vacuum is to the solidification point in accordance with the vapour pressure curve above ice, the shorter the drying time is.

**Interesting correlations :**

- 1.0 gram of ice at
- 1.0 mbar assumes a volume of 1 m<sup>3</sup> vapour
- 0.1 mbar assumes a volume of 10 m<sup>3</sup> vapour
- 0.01 mbar assumes a volume of 100 m<sup>3</sup> vapour

**Heat Supply during Drying**

The required heat supply to the product to be dried takes place through direct heat contact in the drying chamber, heat conduction through gas or through radiation. Heat transfer by direct contact and heat conduction through gas are the most usual sources of heat in today's freeze dryers. The constraints caused by the former can be seen in the following diagram.

**Effects of freeze drying of a product in a dish**

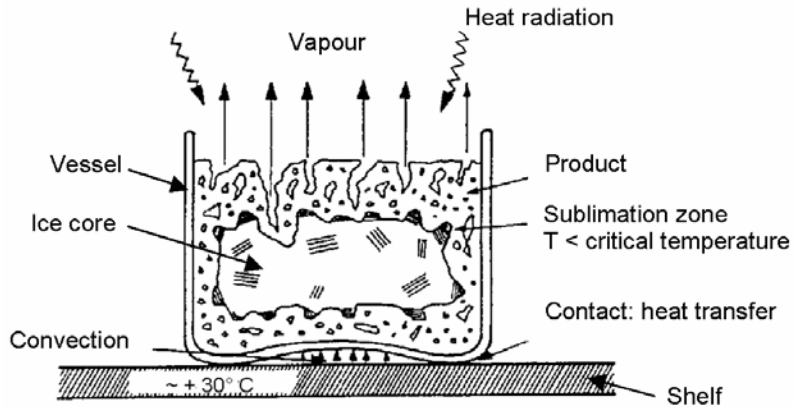

Heat transfer takes place via the heated shelves by direct contact with the bottom of the vessel and/or by convection via the shelf and vessel or product.

At the beginning of sublimation the transfer of heat is very effective from the wall of the vessel to the frozen product. However, soon an area develops which is ice free, porous and dried and has a corresponding temperature gradient between the wall of the vessel and the product. The poor heat conductivity of the already dried product can lead to an increase in temperature of the ice core. If the core temperature rises above the solidification temperature, the product begins to thaw. This applies especially to inhomogeneous products and to great layer thicknesses. During this drying phase it is important to regulate the heat supply and control temperature and pressure precisely.

---

## 2.5. Final Drying

The final pressure in the drying chamber depends on the ice condenser temperature according to the vapour pressure curve above ice :

- e. g. 1.030 mbar correspond to -20°C
- 0.370 mbar correspond to -30°C
- 0.120 mbar correspond to -40°C
- 0.040 mbar correspond to -50°C
- 0.011 mbar correspond to -60°C

The unit is in operating condition if the temperature of the ice condenser is lower than -50°C and the pressure is lower than 0.120 mbar.

The final pressure measured by the vacuum sensor when there is no product in the unit and its corresponding ice temperature value is mainly determined by the warmest place of the ice on the ice condenser chamber. Moreover, this value is affected by residues or parts of solvents in the product with a higher vapour pressure.

---

## 2.6. End of Drying and Aeration

A rough indication of the end of drying are the vacuum and the ice condenser temperature. The ice condenser is no longer loaded and reaches the final temperature of approx. -55°C to - 85°C. The pressure in the drying chamber decreases according to the ice condenser temperature.

The vacuum pump is switched off and the drying chamber is vented via a rubber valve or the aeration valve on the left side of the unit. The aeration valve can also be used to “flood” the unit with nitrogen or another inert gas instead of using air.

**CAUTION!** Maximum overpressure 0.2 bar!

Then the unit is switched off and the product is removed.



---

## 2.7. Defrosting

Defrosting of the ice condenser is carried out at room temperature or with warm water. At a maximum the ice condenser chamber may be half filled with water.

When defrosting the ice condenser with (warm) water, it is of crucial importance that no water gets into the pipe connection for the vacuum pump and the vacuum sensor (see figure)!

The condensate as well as the defrosting water are drained through the drain valve at the left side of the unit. To do this, a hose is put onto the nozzle. The condensate and the defrosting water are collected in a vessel.

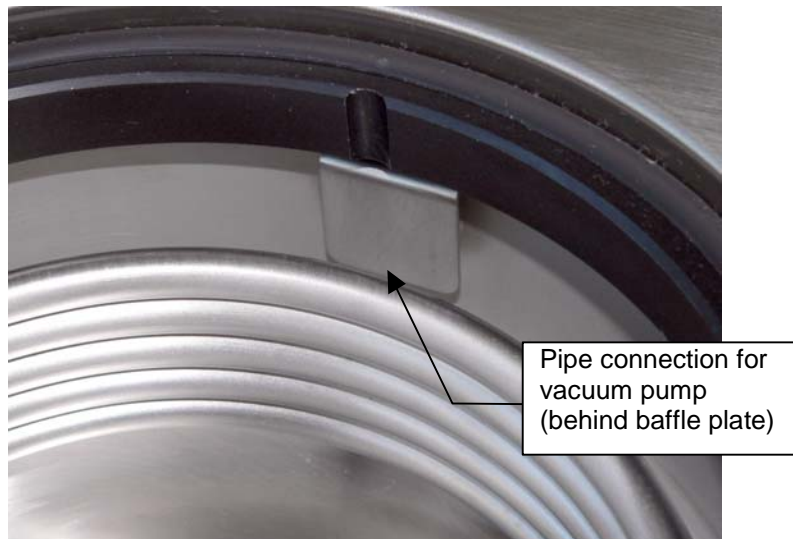

# 3. Description of the Freeze Drying Processes

---

## 3.1. Separate Freezing and Drying Outside the Ice Condenser Chamber (Process B) on Shelves

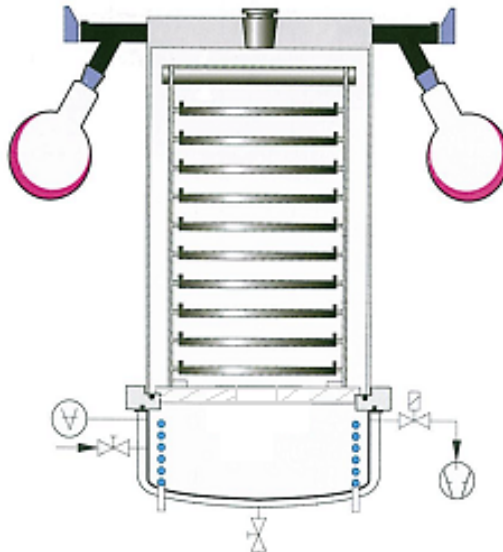

It is also possible to dry the product outside the ice condenser chamber. In this case, the product has to be frozen e.g. in a deep-freeze.

Possible water residue is removed from the ice condenser chamber. The drain valve is opened so that the water residue can drain off. The ice condenser chamber should be wiped out if necessary.

The refrigeration compressor and the vacuum pump are activated via the control system to start the pre-freezing of the ice condenser and the warming-up of the vacuum pump. The valve is closed during warming-up of the pump. In case the unit is not equipped with an electromagnetic pressure control valve we recommend to use a

manual stop valve. Without such a valve the vacuum pump must not be warmed up.

The rack is set onto the base plate. With small samples it is recommended to pre-cool the shelves. In this way, a partial thawing during the evacuation process is avoided.

When freezing and drying is performed separately outside the ice condenser chamber it is directly started with the main drying process.

As soon as the shelves with the frozen samples have been put in, the unit and the drying chamber are sealed and the process is started. To do so, the main drying process has to be activated in the control system so that the pressure control valve opens and the main drying process starts (see chapter 5.6).

When the pressure is lower than the pre-selected „**Safety pressure heating unit**“ the heating of the shelves is activated. The heating unit continues to be switched on until the nominal value of the shelf is reached.

---

### 3.2. Separate Freezing and Drying Outside the Ice Condenser Chamber (Process B) with Sealing Device

Possible water residue is removed from the ice condenser chamber. The drain valve is opened so that the water residue can drain off. The ice condenser chamber should be wiped out if necessary.

The refrigeration compressor and the vacuum pump are activated via the control system to start the pre-freezing of the ice condenser and the warming-up of the vacuum pump. The valve is closed during warming-up of the pump. In case the unit is not equipped with an electromagnetic pressure control valve we recommend to use a manual stop valve. Without such a valve the vacuum pump must not be warmed up.

The rack is set onto the base plate. With small samples it is recommended to pre-cool the shelves. In this way, a partial thawing during the evacuation process is avoided.

The sealing device is used to seal injection bottles under vacuum or inert gas with ribbed rubber stoppers. Depending on the type of sealing device the bottles are sealed on 1 to 2 shelves. To do this, the shelves are moved against each other by a pressure plate using a spindle.

The height of the pressure plate must be adjusted according to the height of the bottles. To do so the threaded pin for height adjustment is removed. The threaded rod is screwed into the lower shelf until its slotted head is on the same height as the rack (upper edge).

Then the pressure plate is fastened with the threaded pin in such a way that it will rest on or slightly above the rubber stopper. When using two or more shelves every shelf is set directly on or with a slight distance to the rubber stoppers as it is the case for the pressure plate.

Instead of the stopper the vacuum-tight rotary leadthrough is put into the standard ground socket of the drying chamber. Before inserting, the ground-in surface of the leadthrough is greased with vacuum grease.

After completion of the drying process the lever of the rotary leadthrough is turned to the right until a resistance is felt.

For the sealing of the bottles the shelf must be completely filled. For small quantities at least three spacers must be evenly put on each shelf (according to the height of the bottles with inserted rubber stoppers).

The appropriate spacers are available upon request.

---

### **3.3. Separate Freezing and Drying of Liquids in Flasks (Process B)**

Possible water residue is removed from the ice condenser chamber. The drain valve is opened so that the water residue can drain off. The ice condenser chamber should be wiped out if necessary.

The refrigeration compressor and the vacuum pump are activated via the control system to start the pre-freezing of the ice condenser and the warming-up of the vacuum pump. The valve is closed during warming-up of the pump. In case the unit is not equipped with an electromagnetic pressure control valve we recommend to use a manual stop valve. Without such a valve the vacuum pump must not be warmed up.

Several manifolds and mountable drying chambers with several connections for rubber valves are available for the drying process outside the ice condenser chamber (see accessories catalogue). The drying chamber with connections for rubber valves is mounted directly to the sealing ring of the base plate. Manifolds with outer ground joints NS 45/40 are connected via the ground-in socket of the acrylic lid.

In order to ensure a vacuum-tight connection and to simplify the removal of the named accessories the ground-in surface must be slightly greased with vacuum grease before use. The manifold or drying chamber is mounted afterwards and turned by 360° for an even distribution of the grease.

The ground-in surfaces have to be cleaned and greased before every further mounting of accessories.

Before the drying process can start it is necessary to check that all valves are closed.

To start the drying process, the main drying process has to be activated in the control system. The pressure control valve opens and the main drying process starts.

**Caution:**

The frozen samples can only be connected to the valves when a pressure of less than 1.030 mbar is reached.

Liquids are frozen in flasks according to the shell freezing principle, manually or with a turning device. Thanks to this freezing process the layer thickness is reduced and the drying period is considerably shortened.

Most of the manifolds and valves available allow a continuous connection and removal of flasks during the drying process. Each rubber valve is equipped with a closing and aeration valve.

If the rubber valves or stainless steel valves are stiff they must be dismantled, cleaned, slightly greased with vacuum grease and reassembled.

It is also possible to connect a distributor for 15 ampoules to every rubber valve.

Using a distributor a maximum of 15 ampoules can be simultaneously frozen in the cooling bath and connected to the manifold.

---

### **3.4. Separate Freezing and Drying of Liquids in Ampoules (Process B)**

The refrigeration compressor and the vacuum pump are activated via the control system to start the pre-freezing of the ice condenser and the warming-up of the vacuum pump. The valve is closed during warming-up of the pump. In case the unit is not equipped with an electromagnetic pressure control valve we recommend to use a manual stop valve. Without such a valve the vacuum pump must not be warmed up.

The manifold is equipped with blind plugs for connection of a maximum of 48 ampoules so that it can be pre-evacuated.

The first hose is clamped in the middle with the supplied hose clamp and the blind plug is removed. The vacuum of the system is preserved.

The liquid in the ampoule is either frozen under rotation in a cooling bath or in a deep-freeze.

If shock-freezing is required we recommend that freezing is carried out in liquid nitrogen or in a cooling bath.

The ampoule is then connected to the hose and the hose clamp is removed. Thus the partial pressure in the ampoule is suddenly decreased and a partial thawing during the evacuation process is avoided.

One ampoule after the other is connected using this method.

Sealing of the ampoule is carried out in the same way. The hose of the ampoule to be sealed is clamped and the ampoule is sealed under vacuum using the blow lamp.

If the ampoule breaks during sealing the vacuum in the drying chamber is not affected due to the clamping with the hose clamp.

The remaining glass from the ampoule is removed and the hose is closed with a blind plug.

In this way one ampoule after the other can be sealed or new ampoules can be connected.



# 4. Installation and Commissioning of the Unit

---

## 4.1. Site of Installation



**WARNING!** Papers, cloths or similar items must not be put behind the unit as the air circulation of the heat exchanger will not work any more.

The freeze dryer should be horizontally aligned. The ambient temperature should be within approx. +10°C and +32°C.

The refrigeration compressor of the freeze dryer is air-cooled. Sufficient air circulation must be ensured. A distance of at least 30 cm to the wall should be kept. The unit should not be positioned near radiators or heat sources and direct insolation must be avoided.

In case of insufficient air circulation or too high ambient temperatures pressure and/or temperature in the refrigerating system will increase. This may cause an exceeding of the admissible operation pressure and thus a breakdown of the freezing unit.



The following connections are required at the site:

---

## 4.2. Mains Electricity

The voltage given on the name plate must correspond to the local supply voltage.

CHRIST freeze dryers are units of safety class I and include a three-conductor connection cable and a shockproof plug.

---

## 4.3. Fuses on Site

The freeze dryer must be protected typically with a 16 AG fuse.

---

## 4.4. Checking the Earth Connection

For checking the earth connection there is a screw for equalising the ground potential on the back panel of the freeze dryer. The check can be carried out by means of an appropriate measuring device.

---

## 4.5. Aeration

The aeration and drain valve at the lower left side of the unit is used to vent the ice condenser chamber.

In case penicillin bottles have to be sealed under nitrogen instead of vacuum, the ice condenser chamber can be flooded with nitrogen via the nozzle of the aeration valve.

CAUTION! Max. 0.2 bar overpressure!

---

## 4.6. Condensate and Defrosting Water

The condensate and defrosting water is drained via the aeration and drain valve on the lower left side of the unit. To drain the water, connect the hose supplied with the unit to the nozzle. The condensate and defrosting water are collected in a vessel.

The condensate and defrosting water can also be drained directly via this hose. The condensate and defrosting water must be able to drain freely. To achieve this, the hose must have a steady downward slope. It must be ensured that water does not collect in any part of the hose. The end of the hose always has to be above the level of the liquid in the vessel for the discharged liquids. Otherwise there is the risk of water and dirt residues being sucked into the ice condenser chamber if there is a negative pressure when opening the drain valve.

The drain valve is also used to vent the unit when a freeze drying process has been completed.

---

## 4.7. Vacuum Pump Exhaust

During the main drying phase the separate vacuum pump must be operated with open gas ballast valve. The oil mist which is produced must be removed.

A ½" hose can be connected to the exhaust flange of the vacuum pump RZ-2 or RC-5 and a ¾" hose is connected to the exhaust flange of the vacuum pump DUO 5 or DUO 10. The hose either leads into the open air or into a vent.

During installation of the pipe care must be taken that condensate cannot flow back into the pump. With upward leading pipes it is safest to use a separator (Woulfe's bottle or wash bottle) in the pipe.

We strictly recommend using an exhaust filter (oil mist separator). This filter prevents air pollution by oil mist which is emitted by the vacuum pump in different quantities depending on the working pressure.

The filter is fastened to the exhaust flange of the vacuum pump.

The filter is equipped with a pressure relief valve indicating the saturation of the filter. Cleaning or replacing of the filter insert must be carried out at the latest when the pressure relief valve is activated. The collected oil is visible in the inspection glass and is drained via the discharging screw.

(Please refer to separate operating manual of the vacuum pump!)

---

## 4.8. Initial Start-up

**CAUTION!** Ensure that the freeze dryer is correctly mounted and installed before initial start-up (see point 4.1 Site of Installation and following points).

## 4.8.1. Functional Components and Control Elements



## 4.8.2. Connection of Vacuum Pump and Installation of Accessory Components

### 4.8.2.1 Connection diagram ALPHA 1-2 LD<sub>plus</sub>

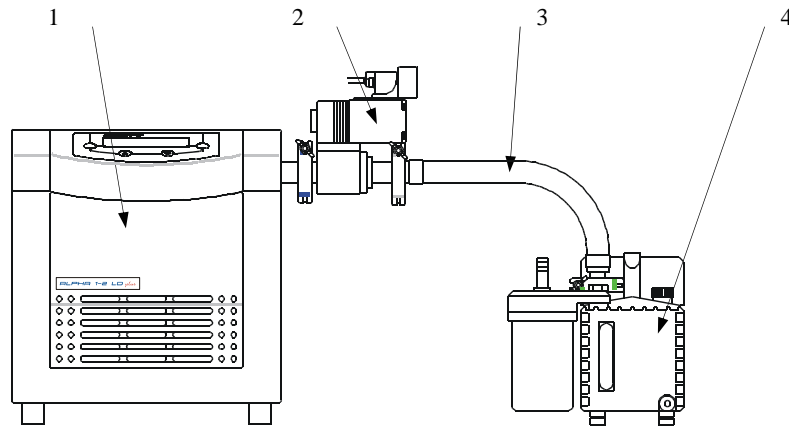

- 1 ALPHA 1-2 LD<sub>plus</sub>
- 2 Pressure control valve and stop valve
- 3 Vacuum hose
- 4 Vacuum pump

The accessory components are connected to the **ALPHA 1-2 LD<sub>plus</sub>** freeze dryer according to the connection diagram shown above.

Centring rings and clamping flanges with wing nuts are used as connecting elements (small-flange connection according to ISO 28403 or DIN 2861, see the following instructions).

### Instructions for the connection with centring rings and clamping flanges

Small flange connections which are not mounted properly between the aggregates or to connect hoses are often the reason for serious vacuum problems.

Please loosen the connection and replace the centring ring (with sealing ring inside) centrally between the flange connections. Seal the connection with the clamping flange by fastening the wing nut.

Please take care that the centring ring does not get out of place and does not tilt.

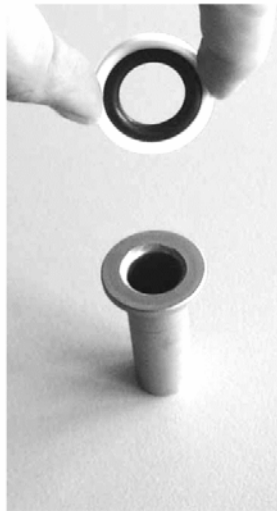

Small flange and centring ring

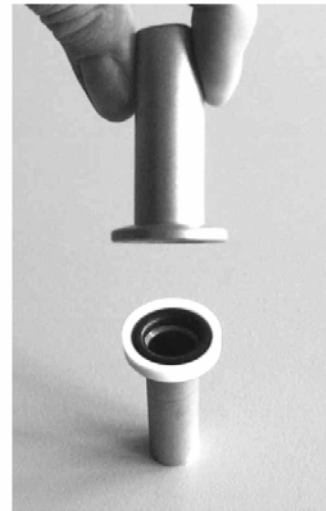

Small flange with centring ring and small flange

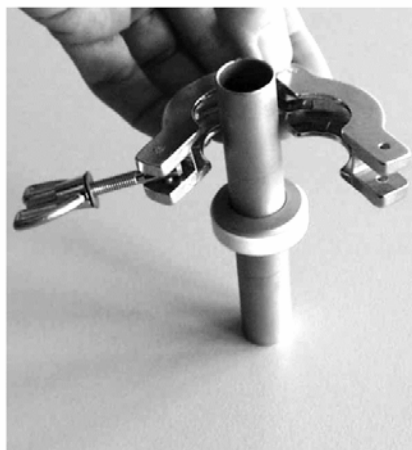

Mounting of the clamping flange

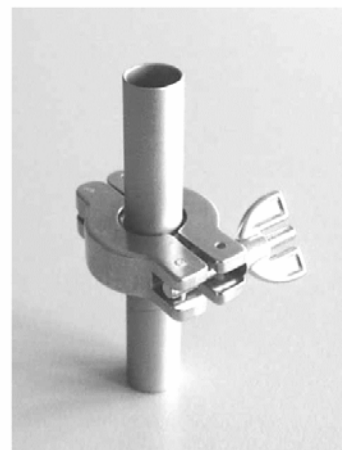

Fastening of the clamping flange

In case a pressure control valve is available it has to be mounted between the freeze drying unit and the vacuum pump. Then it has to be plugged into the socket of the freezing unit on the rear panel of the unit.

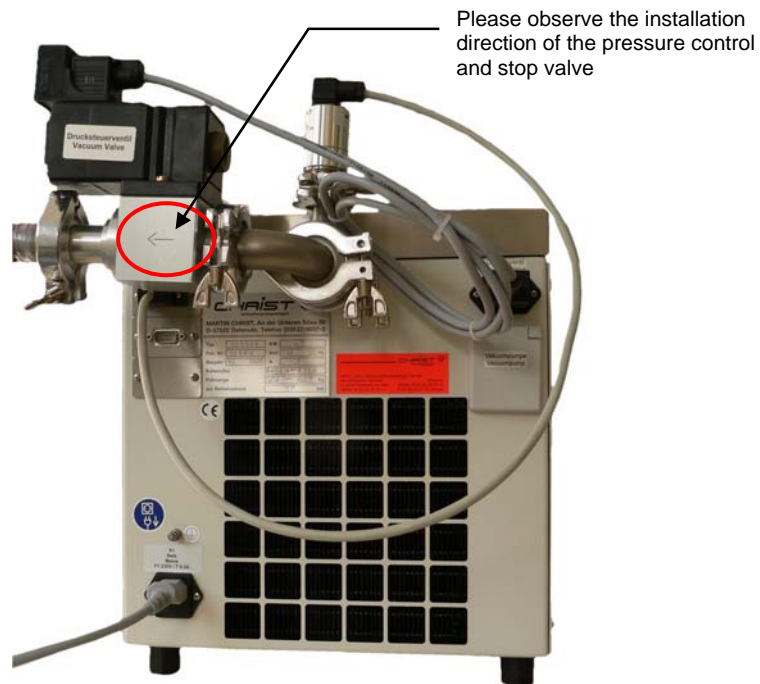

The vacuum pump is connected to the unit and plugged into the socket on the rear panel of the unit.

The vacuum gases shall be filtered or drained.

The aeration valve and the drain valve on the left side of the unit have to be closed.

The lid or the drying chamber has to be mounted to the ice condenser chamber.

In case the drying chamber is equipped with rubber valves they have to be closed.

Further accessories (e.g. shelves, connections for round bottom flasks) are added accordingly.

### Diagram of the accessories

The other accessories (e.g. drying chamber, shelves, and connections for round bottom flasks) will be completed according to the scope of supply.

**Example:** Accessories for drying on 2 unheated shelves with sealing device for injection bottles (without vacuum pump).



**Example:** Accessories for drying on 3 unheated shelves plus individually lockable rubber valves for round bottom flasks or wide-neck filter bottles (without vacuum pump).



Possible accessories for the ALPHA 1-2 LD<sub>plus</sub>:

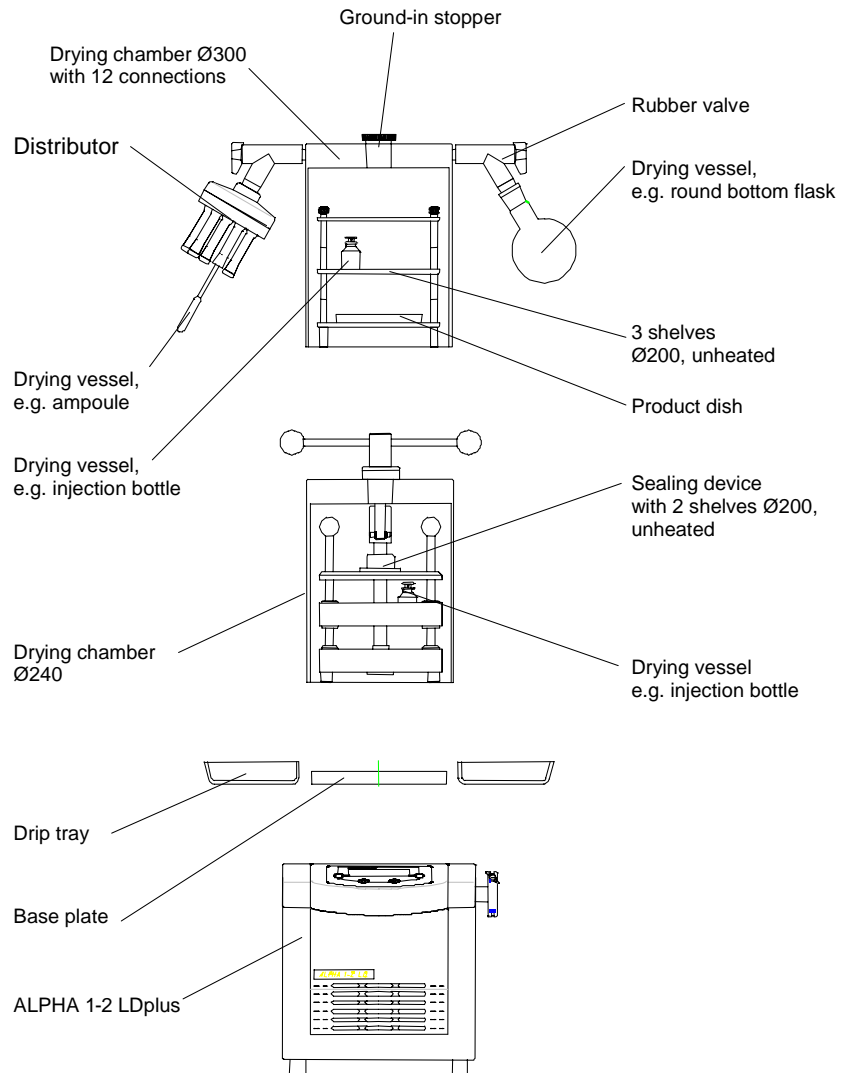





### 4.8.3. Switching-on

Press the mains switch on the right side of the unit to switch the unit on.

The initialization of the LD<sub>plus</sub> control system starts. This may last for several seconds.



When the unit is switched on for the first time (after delivery from the factory), the user will be guided through the LD<sub>plus</sub> control system in the form of a tutorial for a quick familiarisation with the unit.

First select your language using the up  and down  keys and confirm your selection by pressing the Next  softkey.



After this, the user will be guided step by step through the tutorial.

In the end, the program inquires as to whether the user wants the tutorial to be displayed again when the unit is switched on the next time.

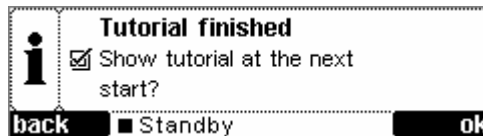

# 5. LDplus Control System

---

## 5.1. Introduction

LDplus (Lyo Display Plus) stands for a convenient user interface for controlling of freeze drying process.

---

## 5.2. LDplus Control Panel

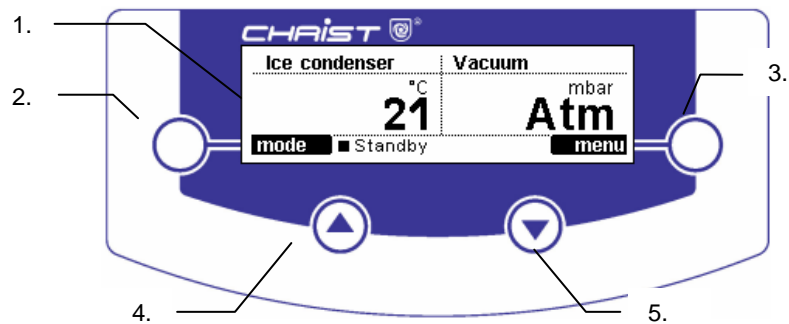











1. Illuminated LC display (240x64 pixels)
2. Left softkey ○■
3. Right softkey ■○
4. Up key ▲
5. Down key ▼

---

## 5.3. Brief Guide - Handling

The LDplus control system is operated via four centrally located keys on the touch-sensitive control panel.

The following functions are assigned to the four key :

- Left softkey  & right softkey   
Softkeys are keys with dynamic functions assigned to them. The current key function is displayed next to the key. Softkeys allow the control system to be operated in a particularly easy and transparent way.
- Up key  & down key   
The up key  and the down key  are used to select set value and actual values to be displayed in the values window. The up key  is assigned to the left-hand values window and the down key  to the right-hand values window. If one of the keys is pressed, the system scrolls through the available set values or actual values. Inside the menu, the up key  and the down key  are used to shift the focus. When parameters are entered, they are used to change the value.

## 5.4. Visual Components of the LDplus Control System

The LC display is divided into the three following areas:

1. Main window
2. Status bar
3. Softkey function

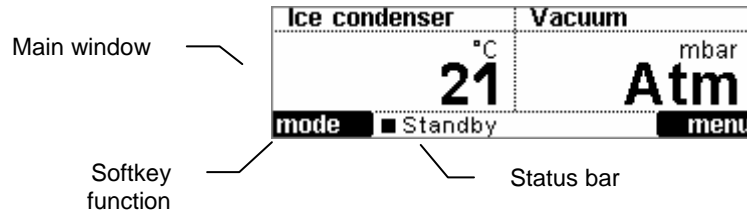

### 5.4.1. Main window

The main window shows set values and actual values, menus and process-relevant information.

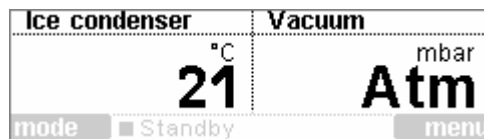

### 5.4.2. Status bar

The status bar shows the current operating mode, the active phase and other relevant information. The status bar is visible at all times.

Structure of the status bar:

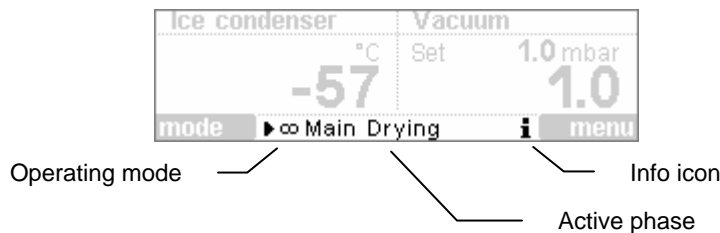

#### 5.4.2.1 Operating mode

- ■ Standby  
The freeze dryer is in standby mode. All aggregates are switched off.
- ▶∞  
The freeze dryer is in run mode. The timer is deactivated.
- ▶⌚  
The freeze dryer is in run mode. The timer is activated.

### 5.4.2.2 Active phase

- Freezing  
The ice condenser is cooled.
- WarmUp VP  
The ice condenser is cooled and the vacuum pump is activated with the pressure control valve closed. If no pressure control valve is installed, the drying chamber has to be shut off from the vacuum pump using a manual valve, for example.
- Main drying  
The drying chamber is evacuated with the ice condenser being cooled. If a pressure control system is included, the vacuum is controlled with the corresponding set value for main drying.
- Final drying  
The final drying phase is only available if a pressure control system is included. Different control parameters (set vacuum value, timer) can be defined for main drying and final drying.



### 5.4.2.3 Info icon

The info icon flashes every second to draw the user's attention to error messages, process messages or general information concerning the process or the unit. The message can be displayed in the process and unit information window under Menu -> Process & Equipment Information System.

### 5.4.3. Softkey function

Softkeys are keys with dynamic functions assigned to them. The current key function is displayed in the black field next to the key.



In the screenshot, the left-hand softkey has the function Mode  and the right-hand softkey the function Menu .

---

## 5.5. Values Window

The values window is displayed after the initialisation of the LDplus control system. It is divided into two areas, the left-hand values window and the right-hand values window.

The left-hand and right-hand value windows are structured as follows:

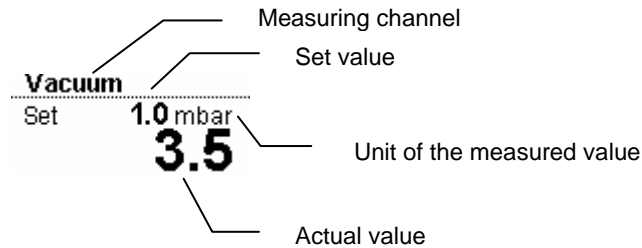



The up key  $\uparrow$  is used to select the measuring channel to be displayed in the left-hand values window. The down key  $\downarrow$  is used to select the measuring channel in the right-hand values window.

The following measuring channels are available:

- Total time  
Counts the time of the entire process run
- Section time  
Counts the time of an individual phase (freezing, warm-up vacuum pump, etc.)
- Ice condenser temperature  
Temperature of the ice condenser
- Vacuum in mbar  
Vacuum in the drying chamber. This measuring channel can only be selected if a vacuum sensor is installed.
- Vacuum converted into °C  
Vacuum in the drying chamber in °C, converted according to the vapour pressure curve above ice for water (see the chapter "General Information on Freeze Drying"). This measuring channel can only be selected if a vacuum sensor is installed.

---

## 5.6. Mode

The mode selection can be activated by pressing the left-hand softkey **Mode**  in the active values window. The function **Mode**  comprises the operating mode selection and the phase selection.



Freeze drying comprises the following four phases:

- Freezing
- Warm-up vacuum pump
- Main drying
- Final drying

### 5.6.1. Starting a drying process

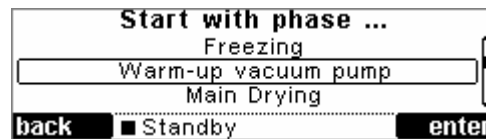
If the unit is in standby mode, pressing the softkey **Mode**  leads to an inquiry concerning the phase to be used for starting the freeze drying process.



If the user wants to start directly with the main or final drying phase, the system inquires as to whether the vacuum pump should be warmed up. This inquiry has to be confirmed by pressing either **yes**  or **no** .

### 5.6.2. Changing the phase

If the unit is in run mode, you can change over to the next phase or stop the process by selecting **Standby**.

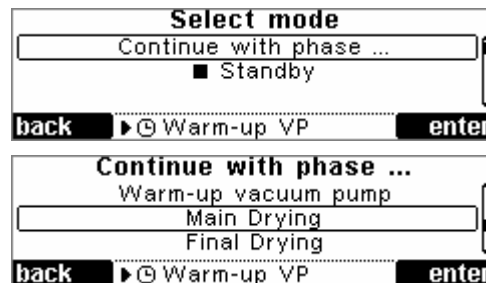

### 5.6.3. Timer

If the timer is active for the phase (timer set value  $\geq$  1 minute), the system inquires before the selected time is over as to whether the user wants to continue with the next phase.

If the last phase is active, the system inquires as to whether the process should be continued or stopped (standby).

To deactivate the timer, select an infinite set value ( $\infty$ ).

As an option, it is possible to change over to the next phase automatically when the preselected time is over.



**This applies only to a phase change from:**

- Freezing  $\rightarrow$  Warm-up vacuum pump
- Main drying  $\rightarrow$  Final drying

The option can be activated under Menu  $\rightarrow$  Options  $\rightarrow$  Settings  $\rightarrow$  Automatic phase change.

---

## 5.7. Main Menu

The main menu can be activated by pressing the right-hand softkey Menu  $\blacksquare$ - $\bigcirc$  in the active values window.

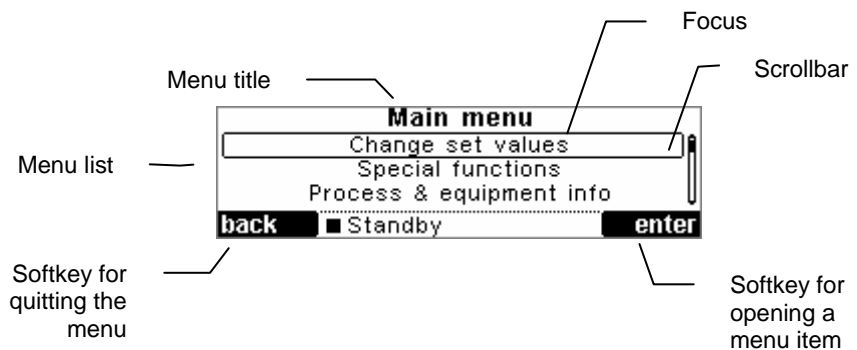

The following section explains all menu items in detail:

### 5.7.1. Change set values

Used to define the phases freezing, main drying and final drying.

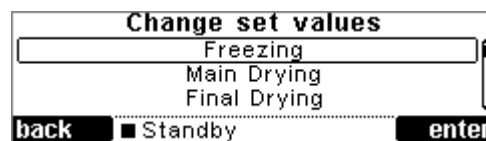

First select the phase.





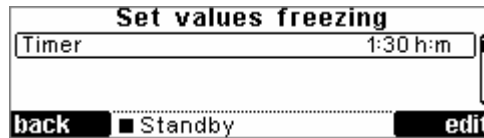

Select the set value using the focus.

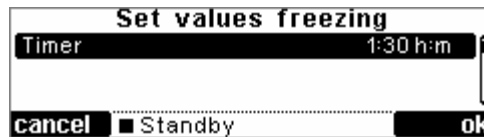

Press the right-hand softkey **Edit**  to start the editing mode. The focus is displayed in an inverted manner. You can now change the set value within a permissible range using the up  and down  keys.



Press **OK**  to confirm the set value or **Cancel**  to reject it. The editing mode is quit.

### 5.7.1.1 Set values for freezing

- **Timer**  
Time for the freezing phase section time. You can set a time between 1 minute and 200 hours. Selecting the infinite set value ( $\infty$ ) deactivates the timer for the freezing phase.

### 5.7.1.2 Set values for main drying & final drying

- **Timer**  
Time for the main or final drying phase section time. You can set a time between 1 minute and 200 hours. Selecting the infinite set value ( $\infty$ ) deactivates the timer for the main or final drying phase.
- **Vacuum**  
Set value for the control vacuum in the drying chamber during main or final drying. The pressure control option must be installed. You can set a value between 6.1 mbar and 0.0010 mbar converted into steps of 1°C according to the vapour pressure curve above ice for water.

Set values for final drying are not available unless the pressure control option is installed.

## 5.7.2. Special functions

The special functions menu is used to operate special accessories (defrosting device and electrical lifting device) of the freeze dryer.

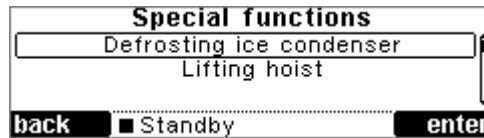

If one of the options is not installed in the freeze dryer, the system displays the message *Option not available*.

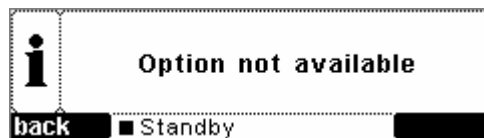

A detailed description of the special functions can be found in the chapter "LDplus Special Functions".

## 5.7.3. Process and Equipment Information System

Further information can be found in the chapter "Process and Equipment Information System".

## 5.7.4. Options

The Options menu includes the functions Contrast, Language, Settings and Service.



### 5.7.4.1 Contrast

The Contrast menu is used to change the contrast of the LC display. The contrast has to be adapted to the local light conditions at the installation site of the freeze dryer.

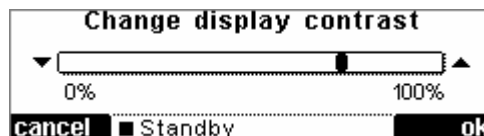

### 5.7.4.2 Language

The LDplus control system can be used in the German, English or French language.



### 5.7.4.3 Settings

The Settings menu is used to customise the operation and process management of the control system.

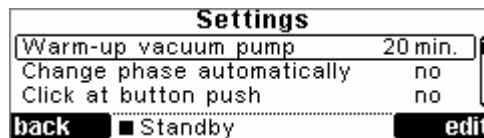

#### Warm-up vacuum pump

Warm-up time required by the vacuum pump. In case of doubt, please refer to the operating manual of the vacuum pump. You can set a warm-up time between 5 and 60 minutes.

#### Automatic phase change

The system automatically continues with the next phase when the preselected time is over (timer active).



**This applies only to a phase change from:**

- Freezing ⇌ Warm-up vacuum pump
- Main drying ⇌ Final drying

#### Click upon key depression

A brief signal can be heard whenever a key is pressed.

#### High temperature resolution

Temperature are displayed in the values window with a resolution of  $\frac{1}{10}^{\circ}\text{C}$ , normally with a resolution of  $1^{\circ}\text{C}$ .

#### Defrost ice condenser

Time required for defrosting the ice condenser

### 5.7.4.4 Service

The service menu is reserved for the service engineer.

This area is password-protected and not available to the user.

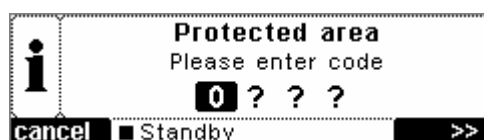

## 5.7.5. Tutorial

Starts the tutorial of the LDplus control system.



## 5.8. Process and Equipment Information System



A detailed list of error messages can be found in the chapter "Error Correction".

The process & equipment information window is displayed whenever the LDplus control system generates a new information message. In addition, the user can select Menu -> Process & Equipment Information System in the main menu to check whether messages are pending.

If no messages are pending, the following window is displayed.

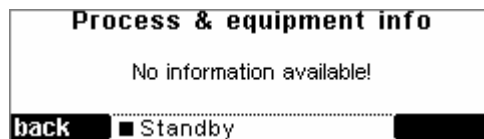

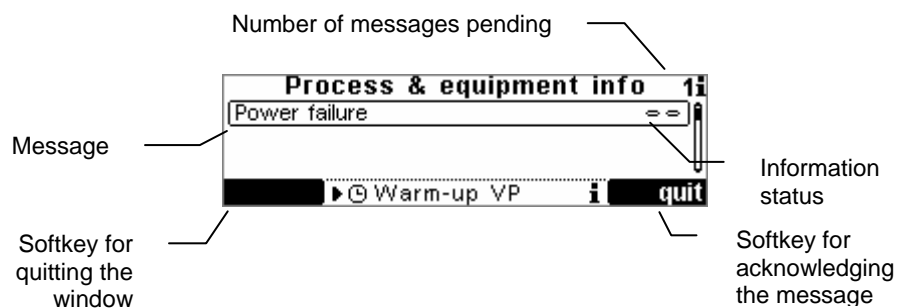

When a message is generated, a signal can be heard, the information icon **i** appears on the status bar and the process & equipment information window is displayed. If the user is working in a menu, the process & equipment information window will not be displayed until the user quits the main menu.



### 5.8.1. Information status

Every information shown in the process & equipment information window receives a certain status.

-  = Information present, not acknowledged
-  ✓ Information present, acknowledged
-  = Information no longer present, not acknowledged

Once an information is no longer present but has been acknowledged, the information will be removed from the process & equipment information window.

The signal continues until all pieces of information are acknowledged.

In order to quit the process & equipment information window, you have to acknowledge all pieces of information so that the softkey Back  can be displayed.

---

## 5.9. LDplus Special Functions

### 5.9.1. Defrost ice condenser (option)

During defrosting, the ice condenser chamber is heated electrically. The heat released by the chamber melts the ice deposited on the ice condenser.

Open the menu Menu -> Special functions -> Defrost ice condenser.



**In order to defrost the ice condenser, the unit must be in standby mode and completely aerated.**

Press the right-hand softkey Start  to start the defrosting process. The following window is displayed. It shows the progress of the defrosting process.

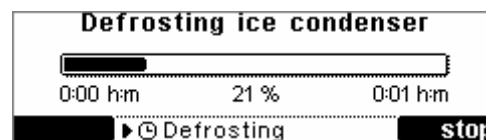

When the defrosting time is over, the defrosting process is stopped and the window is closed.

You can set the time required for defrosting under Menu -> Options -> Settings -> Defrost ice condenser.

## 5.9.2. Electrical lifting device (option)

To move the drying chamber with the help of the electrical lifting device, open the menu Menu -> Special functions -> Electrical lifting device.



**In order to move the drying chamber, the unit must be in standby mode and completely aerated.**

Use the up  and down  keys to move the drying chamber.

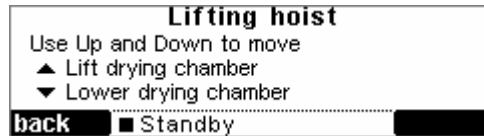



# 6. Error Correction

---

## 6.1. Power Failure

The control system continues the process after a power failure. The preselected conditions remain saved during the process run. The process times, the total time and the section time are reset.

In the event of a power failure during the drying process the batch may become unusable. Whether the batch can be saved depends on the drying phase in which the product was when the power failure occurred.

It is important to distinguish between the main drying and final drying phase:

The product is in the final drying phase when the residual moisture has reached approx. 5 %. Below this value the product is generally not damaged in the event of a power failure.

If the product is in the main drying phase we recommend that the unit is vented, the product taken out and stored in a deep-freeze. Before further operation the defrosted condensate must be drained.

---

## 6.2. Insufficient Vacuum

Special attention must be paid to the high-vacuum valves. The drain valve, the micro-aeration valve and the rubber valves must be checked.

We recommend that after disconnecting the mains plug the left side panel of the unit is unscrewed and then the hose inside the unit is detached from the drain valve, the pipe connection is sealed with a rubber stopper, and the unit evacuated. If the unit will now reach the necessary operating pressure there is a leakage in the valve. This is caused by residue from the drying process, fluff from cleaning cloths or wear and tear of the O-rings of the valve.



To eliminate this fault we recommend that the unit is evacuated and vented by means of the drain valve so that any residue (e.g. collected parts) is removed. If necessary, the O-rings must be replaced.

If the leakage cannot be eliminated in this way, the drain valve must be cleaned or replaced.

Check the sealing of the lid for dirt or damages. If necessary, the sealing must be cleaned or replaced.

Check if the whole surface of the ground-in socket of the mountable drying chamber has been greased evenly and completely with vacuum grease.

When using drying chambers with several connections for rubber valves the valves should be taken off and the connections should be sealed with rubber stoppers. To check the valves they are connected one after the other and tested under vacuum.

Check the vacuum sensor for pollution such as water residue.

The vacuum sensor has a limited life time due to its design principle (see also chapter 7.3.1). Vacuum sensors are available as a spare part.

Check the vacuum display with a suitable testing unit (if available).

In order to locate a possible leak we recommend that the vacuum measuring sensor is directly connected to the vacuum flange of the vacuum pump. If the warm vacuum pump reaches a final pressure of at least 0.011 mbar, the vacuum pump and the measuring system can be presumed to be in working order. There is probably a leak in the unit if insufficient vacuum is not caused by an insufficient ice condenser temperature.

Check the oil level in the vacuum pump, change oil if dirty, and carry out a pressure test.

If the above-mentioned steps show no result, the next step is to check all small flange connections (see chapter 4.7.2) and especially the position of the centering rings. It is usually not necessary to grease the sealing rings with high vacuum grease.

The vacuum pump does not switch on:

The vacuum pump is equipped with a protective switch for the drive motor.

(Please refer to separate operating manual).

General information:

The vacuum checks should be carried out when the ice condenser is deep-frozen.

---

## 6.3. Unit does not function

If the display does not work after operating the mains switch, the following must be checked:

Is the mains switch plugged in?

- Check the on site fuses.
- Check the automatic circuit breaker 1F1 on the back of the unit.

---

## 6.4. Insufficient Ice Condenser Temperature

The refrigerator is equipped with a protection device against overpressure in the refrigerating system and with a thermal motor protection.

The protection devices are released

- with too high ambient temperatures,
- with insufficient air circulation of the heat exchanger of the refrigerating system,
- with overload of the refrigerating system.

The refrigerating system is switched off automatically.

Once the permissible operating conditions are reached again (after a few minutes), the refrigerator is switched on automatically via the motor protection switch or via the pressure protection device.

Important errors are shown in the process and equipment information system.

The minimum ice condenser temperature of approx.  $-55^{\circ}\text{C}$  respectively  $-85^{\circ}\text{C}$  is reached if the ice condenser is not loaded and the ice condenser chamber is evacuated.

Sufficient air circulation is necessary. Do not deposit any objects behind the freezing unit!

---

## 6.5. Process and Equipment Information System

### 6.5.1. Error Messages

<b>Vacuum of 6.11 mbar has not been reached</b>
<p>This error occurs in case the pressure in the ice condenser chamber has not reached 6.11 mbar after 15 minutes of operation with open pressure control valve. There must be a vacuum leak in the system. The pump is switched off to avoid it pumping against the atmospheric pressure.</p> <p>The pressure control valve is closed and the vacuum pump is switched off. Please eliminate the error and confirm the message afterwards. Following the confirmation, the vacuum pump is restarted.</p> <p><b>Causes:</b></p> <ul style="list-style-type: none"><li>• Micro-aeration valve or drain valve not closed.</li><li>• Lid or drying chamber not mounted correctly.</li><li>• Missing ground-in stopper in the lid or in the drying chamber.</li><li>• Defective vacuum pump. Check whether the mains switch of the vacuum pump is switched on.</li></ul>
<b>Vacuum sensor defective</b>
<p>This error message is displayed in case the unit control system reads in an invalid value supplied by the vacuum sensor.</p> <p>Check the connecting cable and the connections to the vacuum sensor, perform an atmospheric adjustment of the sensor or replace the vacuum sensor if necessary.</p> <p><b>Causes:</b></p> <ul style="list-style-type: none"><li>• Vacuum sensor not connected.</li><li>• Heating spiral of vacuum sensor broken.</li></ul>
<b>Overpressure refrigerator 1</b>
<p>Overpressure in refrigeration unit KM1, released via the pressure switch.</p> <p>Please check the ambient temperature, ensure sufficient air circulation of the heat exchanger of the refrigeration system and check the load of the unit.</p>
<b>Overpressure refrigerator 2</b>
<p>Overpressure in refrigeration unit KM2, released via the pressure switch.</p> <p>Please check the ambient temperature, ensure sufficient air circulation of the heat exchanger of the refrigeration system and check the load of the unit.</p>
<b>Excess temperature "ice condenser"</b>
<p>This error occurs in case the temperature of the ice condenser exceeds +65°C. All active aggregates are switched off simultaneously, i.e. the system is automatically switched to standby mode. The error message can occur when the temperature of the ice condenser exceeds +65°C when defrosting the system. The refrigerating unit is switched off in order to prevent it from being operated or started at too high temperatures. The system cannot be restarted until the ice condenser temperature is lower</p>

than +65°C.
<b>Temperature sensor “ice condenser” defective</b>
This error occurs in case the temperature sensor is not connected properly or in case it is defective. Please contact our service department.
<b>Temperature sensor “defrosting heater” defective</b>
This error occurs in case the temperature sensor is not connected properly or in case it is defective. Please contact our service department.
<b>Mains failure</b>
The system detects a mains failure when the power supply is interrupted under operating conditions (run mode). Once power supply is re-established, the process will be continued. Process times will be reset to zero. Set values for control purposes remain unaffected.
<b>Factory settings loaded</b>
All settings are reset to the delivery status of the unit. The factory settings are loaded in case the corresponding command is executed in the service menu or in case of an error in the parameter memory.
<b>IO communication error (0x20)</b>
Error in the IO module LDplus EA Please contact our service department.



# 7. Maintenance

---

## 7.1. Ice Condenser Chamber

Before each start-up ensure that all water residue has been removed from the ice condenser chamber. If necessary, wipe the ice condenser chamber.

Before every drying process it is recommended to open and close the drain valve once.

---

## 7.2. Heat Exchanger

A laminated heat exchanger is used to cool the refrigerant compressed by the refrigerator. The heat exchanger is placed at the back of the unit. In intervals of a few months it must be checked for dust or dirt residues and cleaned if necessary. Cleaning of the heat exchanger can be carried out best by brushing, by using a vacuum cleaner from the outside or by using compressed air from inside the unit.

Excessive dirt on the heat exchanger leads to a decrease in performance and can lead to a failure of the unit!

**Please note:** The unit must not be turned upside down!

---

## 7.3. Adjustment and Maintenance of the Vacuum Sensor VSP62

### 7.3.1. Maintenance of the Vacuum Sensor:

The tungsten wire has a limited service life because it easily reacts with ambient gases. Tungsten reacts especially with carbons to build tungsten carbide. The wire becomes short and breaks. Therefore, the only possibility to enlarge the service life of PIRANI sensors is to a v o i d every contact to carbonic substances.

At the end of the drying process vent the freeze drying unit and remove the dry product. Then defrost the unit with open drain valve with warm water (max. +50°C). Finally it is necessary to wipe the ice condenser chamber dry.

It is n o t recommended to defrost the unit simply by leaving it at room temperature over a long period of time. In this case the tungsten wire reacts with the ambient atmosphere!

After defrosting and drying the unit, it is additionally recommended to evacuate the unit for 30 minutes with o p e n gas ballast valve. All residues that may harm the tungsten wire are removed in this way.

### 7.3.2. Replacement and adjustment

The vacuum sensor has to be replaced if “---“ is shown in the vacuum field after the aeration of the system instead of “Atm” and if the process and equipment information window shows the message “Vacuum sensor defective”. If after the warm-up phase and the aeration of the unit the vacuum display still does not show “Atm” but a value equal to or smaller than 900 mbar, the vacuum sensor has to be readjusted. The warm-up phase of the vacuum sensor takes at least 5 minutes.

#### 7.3.2.1 *Vacuum sensor adjustment*

The vacuum sensor has two adjustment buttons labelled “adj” and “set”. The buttons are protected by protective caps. Remove the protective caps of the buttons prior to adjusting the sensor. Use a small pen (max. Ø 2.5mm) to actuate the buttons. Refit the protective caps after the adjustment.

A digital readjustment to atmospheric pressure (Atm) and zero is possible directly at the vacuum sensor using the button labelled “adj” (adjust). The measuring transducer automatically recognises the adjustment point. If a zero adjustment has to be performed, the actual pressure should be smaller than  $5.0 \times 10^{-5}$  mbar (factory setting). Alternatively, the sensor can also be adjusted to a reference value

(see below). We recommend a warm-up phase of at least 5 minutes before the adjustment.

Buttons with protective caps  
for adjusting the sensor



### **7.3.2.2 Adjustment to a specific zero reference value**

To perform this adjustment, the actual pressure must be lower than  $1.0 \times 10^{-2}$  mbar. After pressing of the button labelled “set”, the actual vacuum field of the LDplus control system shows a value corresponding to the zero adjustment value currently set (factory setting 0.0010 mbar). The button labelled “adj” can now be used to increment this value up to a maximum of  $1.0 \times 10^{-2}$  mbar. As of this value, the output starts again at 0.0010 mbar. When the zero adjustment value is adapted to the applied zero reference value, the new zero reference value will be saved automatically and without any other key depression after 5 seconds and the adjustment will be performed. If from now on the "adj" button is pressed at zero pressure, the system will be adjusted to the zero adjustment value set.

If “set” is entered without any other key depression, the zero adjustment value will be shown in a purely informative manner for 5 seconds, but no adjustment will be performed.

---

## **7.4. Rubber Valves**

Special attention must be paid to the rubber valves. If the valves are stiff, they must be dismantled, cleaned, slightly greased with vacuum grease and reassembled.



---

## 7.5. Vacuum Pump

For maintenance of the vacuum pump please refer to the separate operating manual.

Additionally, we would like to emphasise the following points:

The oil level of the vacuum pump must be regularly checked using the inspection glass (in case of continuous operation at least once a week). Top up oil to the required level via the oil inlet. Due to the continuous operation with gas ballast oil consumption cannot be avoided. For topping-up see the operating manual of the pump.

The first oil change must be carried out after approx. 100 operating hours. Subsequent oil change intervals depend on the operating conditions. In general, an oil change is necessary after approx. 500 to 1000 operating hours.

The oil change should always be carried out with warm pump.

---

## 7.6. Exhaust Filter

If the unit is equipped with an exhaust filter (necessary if the exhaust gases cannot be extracted into the open air or into a vent) take care that the condensate in the filter does not rise too high. The condensate is drained using a waste oil drain screw at the filter.

(Please refer to separate operating manual!)

---

## 7.7. Cleaning

### 7.7.1. Cleaning of the Freeze Dryer

Use soap water or other water-soluble, mild agents for cleaning of the freeze dryer. Avoid corrosive and aggressive substances. Do not use alkaline solutions or solvents or agents with abrasive particles. Remove product residues from the ice condenser chamber using a cloth. It is recommended that the lid to the freeze dryer or drying chamber is left open when the freeze dryer is not in use so that moisture can evaporate.



**If there is the risk of toxic, radioactive or pathogenic contamination, special safety measures must be considered and adhered to.**

## 7.7.2. Cleaning of Accessories

When looking after accessories special safety measures must be considered as these are measures to ensure operational safety and reliability.

Chemical reactions as well as stress corrosion cracking (combination of changing pressure and chemical reaction) can affect or destroy the structure of the metals and plastic parts. Hardly detectable cracks on the surface expand and weaken the material without visible signs. When visible damage of the surface, a crack, a mark or any other change, as well as corrosion is detected, the part in question (shelf, vessel, drying chamber etc.) must be replaced immediately for safety reasons.

Fans, lid seal, vessels, racks, drying chamber and shelves must be cleaned regularly in order to avoid damage.

Cleaning of accessories should be carried out away from the freeze dryer once a week or preferably after every use.



**If there is the risk of toxic, radioactive or pathogenic contamination, special safety measures must be considered and adhered to.**

Aluminium accessories are particularly subject to corrosion. A neutral agent with a pH-value between 6 and 8 should be used for such parts. Alkaline agents (pH > 8) must be avoided. Thus life time is increased and corrosion is reduced considerably.

Careful maintenance through the user increases life time and avoids premature failure of accessories. Damage caused by insufficient care does not constitute a warranty claim.

## 7.7.3. Maintenance of the Aeration Valve and the Drain Valve

Special attention must be paid to the aeration valve and the drain valve. If residues from previous drying processes deposit on them, there is the risk of faulty operation of the freeze dryer. Therefore, take care that no product or other residues will get into the pipe to the aeration valve and the drain valve.

## 7.7.4. Disinfection of Drying Chamber, Lid and Accessories

All usual disinfectants like e. g. INCIDUR, Melisiptol, Sagrotan, Buraton or Terralin (available at laboratory retail suppliers) can be used.

NOTE! Check compatibility with lid and drying chamber; also see enclosure "Chemical behaviour PLEXIGLAS® (acrylic glass).

The freeze dryers and the accessories consist of different materials. A possible incompatibility must be considered. For autoclaving the temperature stability of the individual material must be checked.

Please consult us if in doubt. **If dangerous materials are used, the freeze dryer and the accessories must be disinfected.**

### **7.7.5. Checks by Operator**

The operator has to ensure that the important parts of the freeze dryer relevant for safety are not damaged.

This especially refers to:

- Lid or drying chamber
- Seals
- Oil level of vacuum pump
- Accessories, especially changes like corrosion, wear and tear of material etc.

Furthermore, an earth conductor check must be carried out regularly.

# 8. Options

---

## 8.1. Process Control System LPC-32, Software

Upon request.

See separate operating manual.

---

## 8.2. Process Control System LPC-32, Software with PC hardware

Upon request.

See separate operating manual.

---

## 8.3. LyoLog LL-1 (Documentation Software)

Upon request.

See separate operating manual.

---

## 8.4. LDplus Simulation Tool (Training Software)

Upon request.



# 9. Enclosures

Declaration of conformity 1-2 LD<sub>plus</sub>

---

Operating manual of the vacuum pump (only in case of delivery)

Operating manual of the exhaust filter (only in case of delivery)

---

Brochure "Laboratory Freeze Dryers Routine Processes"

Accessories catalogue "The Accessories for Freeze Drying"

Brochure "Laboratory and Pilot Freeze Dryers Advanced Processes"

---

Chemical Behaviour<sup>®</sup>Plexiglas  
(material of the drying chamber and the lid)

Disinfection spray INCIDUR

(Material of all parts getting in contact with the different media)

---

Return declaration

Declaration of contamination



## Chemical Behaviour

### PLEXIGLAS® GS PLEXIGLAS® XT

The stated behaviour was established for the grades PLEXIGLAS GS 215, 218, 221, 222, 224, 231, 233, 240, 245 and 245B as well as for PLEXIGLAS XT. The extruded materials are, however, attacked more easily by solvents.

For greater chemical resistance, grade PLEXIGLAS GS 209 is recommended.

The data given refer to a test temperature of 23 °C and presuppose stress-free installation.

The behaviour of the material in practice depends largely on the temperature in use. In case of doubt, we advise you to consult us as to the chemical resistance for particular applications.

The results obtained for all products, especially the branded ones, refer to the production batch tested in each case.

#### Paints, etc.

- o Acrylic paints and lacquers
- + Non-aromatic benzines
- Nitrocellulose lacquers
- + Oil paint, pure
- Thinners in general

#### Antistatics

- + HB 155
- + Antistatic fluid and cleaning agent

#### Technical baths

- + Electroplating baths
- + Photochemical baths

#### Building materials and protectives

- Bitumen emulsion
- + Cement
- + Gypsum
- o Hot bitumen
- + Mortar
- + Fied lead

#### Chemicals, solvents, etc.

- a) General
- Acetic acid, concentrated
- o Acetic acid, up to 25%
- Acetone

- + Alum
- + Aluminium chloride
- + Aluminium oxalate
- + Aluminium sulphate
- Ammonia water
- + Ammonium sulphate
- Amyl acetate
- Aniline
- + Arsenic
- + Battery acid
- Benzaldehyde
- Benzene
- + Benzine, pure
- Bromine
- 1-Butanol
- Butyl lactate
- + Butyric acid, up to 5%
- + Calcium chloride
- + Calcium hypochlorite
- Carbon disulphide
- Carbon tetrachloride
- Chlorinated hydrocarbons
- Chloroform, liquid
- o Chlorine water
- Chloroethyl ether
- Chlorophenol
- o Chromic acid
- + Citric acid, up to 20%
- + Copper sulphate
- Cresol
- + Cyclohexane
- Diacetone alcohol
- o Diamyl phthalate
- Dibutyl phthalate
- + Diethylene glycol
- Dioxane
- Ether
- Ethyl acetate
- Ethanol, concentrated
- o Ethanol, up to 30%
- Ethyl bromide
- Ethyl butyrate
- Ethylene bromide
- + Ferric chloride
- + Ferrous sulphate
- + Formic acid, up to 2%
- o Formic acid, up to 40%
- + Glycerol
- + Glycol
- Heptane
- + Hexane
- + Hydrochloric acid
- + Hydrofluoric acid, up to 20%
- + Hydrogen peroxide, up to 30%
- + Iodine, metallic



- + Lactic acid, up to 20%
- + Magnesium chloride
- + Magnesium sulphate
- + Manganese sulphate
- + Mercury
- Methanol, concentrated
- o Methanol, up to 30%
- Methyl ethyl ketone
- Methylated spirits
- + Milk of lime
- + Monobromonaphthalene
- + Nickel sulphate
- + Nitric acid, up to 40%
- Nitric acid, over 40%
- + Oxalic acid
- Perchloroethylene
- + Petroleum ether
- Phenols
- + Phosphoric acid, up to 50%
- Phosphorus trichloride
- Phosphorus, white
- + Picric acid, 1% in water
- + Potassium bichromate
- + Potassium carbonate
- + Potassium chloride
- + Potassium cyanide
- + Potassium hydroxide solution
- + Potassium nitrate
- + Potassium permanganate
- o 2-Propanol
- + Propylene
- Pyridine
- Silicon tetrachloride
- + Silver nitrate
- + Soap solution
- + Soda
- + Sodium bisulphite
- + Sodium carbonate
- + Sodium chlorate
- + Sodium chloride
- + Sodium hydroxide solution, 30%
- + Sodium hypochlorite
- + Sodium sulphate
- + Sodium sulphide
- + Stannous chloride
- + Stearic acid
- + Sulphur
- Sulphur dioxide, liquid
- + Sulphuric acid, up to 30%
- o Sulphurous acid, conc.
- + Sulphurous acid, up to 5%
- + Sulphuryl chloride
- + Tartaric acid, up to 50%
- Thiouyl chloride
- Toluene
- + Triethylamine

- Trichloroacetic acid
- + Turpentine
- + Turpentine substitute
- + Urea, up to 20%
- Xylene
- + Zinc sulphate, aqueous
- + Zinc sulphate, solid
- b) Branded products**
  - o CLOPHEN® T 55, A 60
  - o DEKALIN®
  - o FRIGEN® A 12 (CF<sub>2</sub>Cl<sub>2</sub>)
  - GLYBAL® A
  - + PALATINOL® K
  - o PALATINOL® D, BB new
  - + SANGAJOL®
  - + TERAPIN®
  - TETRALIN®
- Disinfectants**
  - a) General**
    - Carbolic acid
    - + Chlor. lime paste
    - + Hydrogen peroxide, up to 40%
    - o Hydrogen peroxide, over 40%
    - Iodine tincture, 5%
    - + Lugol solution
    - Methylated spirits
    - + Sublimat®
  - b) Branded products**
    - o ATHROL® up to 5%
    - BAKTOLAN®, conc.
    - + BAKTOLAN®, up to 5%
    - + CHINOSOL®, up to 1%
    - CHLORAMIN®, solution
    - CHLORAMIN®, suspension
    - ELMCCID GAMMA®, up to 2%
    - LYSOFORM®
    - + MEFAROL®, up to 1%
    - + MERCKJOD®, up to 1%
    - + MERFEN®
    - + PERRYDROL®
    - + PERODIN®
    - + SAGROTAN®, up to 2%
    - o SAGROTAN®, up to 5%
    - o VALPHANOL®, up to 2%
    - + ZEPHIROL®, up to 5%
- Fertilisers**
  - + NITROPHOSKAO®, various grades
- Fats, oils, waxes**
  - + Animal
  - + Mineral
  - o Silicone oil
  - + Vegetable

- Gases and vapours**
- + Ammonia
  - o Bromine vapours, dry
  - + Carbon dioxide
  - + Carbon monoxide
  - + Chlorine
  - o Chlorine vapours, dry
  - + Exhaust gases containing HCl
  - + Exhaust gases containing HF
  - + Exhaust gases containing H<sub>2</sub>SO<sub>4</sub>
  - + Hydrogen sulphide
  - + Methane
  - + Nitrogen dioxide
  - + Nitrogen monoxide
  - + Oxygen
  - + Ozone
  - + Sulphur dioxide, dry
- Beverages, etc.**
- + Beer, wine
  - + Camomile extract
  - + Chocolate
  - + Fruit juice, milk, coffee
  - o Spirits, up to 30%
  - + Vinegar
  - + Water, mineral water
- Adhesives and sealants**
- Acrylate sealing compound
  - o All-purpose adhesive
  - + Insulating tape
  - o PATTEx® special-purpose glue
  - + PERBUNAN®
  - o PLEXISOL® adhesive
  - o PLEXIT®
  - + PLEXTOL® adhesive
  - Polyurethane sealing compound
  - o Sealing strips (EGO-FERM®, TEROSTA® 81/86)
  - o Silicone
  - Thikol rubber (one-and-two component)
- Cosmetics, etc.**
- Camphor
  - + DIPLONA® hair oil
  - + Face tonic
  - + Glycerine
  - + Hair setting lotion (PRIMAWELL®)
  - Nail varnishes
  - Nail varnish removers
  - o Ointments
  - + Peat water
  - + POLYCOLOR®
  - + Seawater
  - + Soaps
  - o Sprays

- Plastics**
- + Foam plastics
  - Foam plastics, plasticised
  - + Polyamide
  - + Polyethylene
  - + PVC
  - PVC, plasticised
  - + Rubber
  - Rubber, plasticised
- Foods and spices**
- + Aniseed, bay leaf, nutmeg
  - Cloves
  - + Common salt
  - + Honey, pure
  - + Ice cream
  - + Meat, fish
  - + Pepper, cinnamon, onions
  - + Pickles
- Cleaning agents**
- a) General**
- Acids, see under chemicals
  - Alcohol, concentrated
  - o Alcohol, up to 30%
  - Alkalis, see under chemicals
  - + Ammonia solution
  - Benzene, mixture, containing aromatics
  - + Bleach
  - Carbon tetrachloride
  - Methylated spirits
  - Perchloroethylene
  - + Petroleum ether
  - + Soap solution
  - + Soda water
  - Stain remover
  - Trichloroethylene
  - + Turpentine
  - + Turpentine substitute
- b) Branded products**
- + ALIX®
  - + ANTI-STATISCHER KUNSTSTOFFREINIGER UND PFLEGER
  - + BFK® cleanser
  - o COLIMENT®
  - + BOTTCHERIN®
  - + BURMAT®
  - + BURNUSS®
  - + CILLIT-GRUN®
  - + DOR®
  - + DOSTYL®
  - + DOSTLAN®
  - + FAKO® Polish
  - + FAKO® Polishing Paste
  - + FEWA®

- + FRAPPIN®
- + FULLBOX®
- + LAVAPLEX®
- + NULL-NULL®
- + PERSIL®
- + PLEXIKLAR®
- + FRIL®
- + RE®
- + SEIFIX®
- + SIDOLIN®
- + SPECTROL®
- + SPUL®
- + WC-000®

**c) Cleaning agents for pipes and tanks**

- + CALGONIT® D, DA, S
- + NEOMOSCAN® M, M powder
- + Nitroklar GR liquid
- + Nitroklar GR powder
- + F3
- o P3 basic cleaner
- + P 3-dix

**Pesticides**

- Sprays (applied directly)
- o Sprays (applied in the air)
- o Pesticides in aqueous solutions
- + NEXION® stable spray
- + RABOND® stable spray

**Protective coatings (strippable)**

- + DIEGEL® liquid film 23022
- + KOPPERSCHMIDT® covering paste
- o SPRAYLAT

**Other substances**

- + Urine
- Fuel for petrol engines
- o Fuel for diesel engines

**The symbols signify:**

- + = resistant
- o = conditionally resistant
- = not resistant

**Note:**

The commercial products mentioned in columns b), and especially those marked ®, have been tested on our products just once. Different results may be obtained if manufacturers change their formulations.

Our technical advice on the uses of our materials is given without obligation. The buyer is responsible for the application and processing of our products and is also liable for observing any third-party rights. Technical data concerning our products are typical values. Subject to alteration.

® = registered trademark

PLEXIGLAS = registered trademark of Röhm GmbH, Darmstadt

**Important notice**

This is an international English-language information prepared for several markets. It is essential that the selection of particular materials and their methods of use conform with the requirements of national and local Building Regulations. The availability of any particular product should be checked with your supplier.

Material Safety Data Sheet according to 91/155/EEC - ISO 11014-1

Incidur

---

1. Identification of the product and of the company  
-----

Identification of the product:

Incidur

Surface disinfectant for medical inventory and other surfaces  
Medical Devices class IIa.

Company/undertaking identification:

Ecolab Deutschland GmbH, Postfach 130406,  
40554 Düsseldorf, Tel.: 0211/9893-0

The Henkel information service also provides an around-the-clock  
telephone service on telephone No. ++49-(0)211/797-3350 for  
exceptional cases.

2. Composition/information on ingredients  
-----

Declaration according recommendation 89/542/EEC:

5 - 15 %: anionic surfactants,  
below 5 %: nonionic surfactants,

Further ingredients: Antimicrobial agents, cleaning booster,  
complexing agent, dyestuff, fragrances.

Declaration of ingredients:

8,8 % Glyoxal  
Symbol: Xn  
R-phrase: 20-36/38-43-68  
EINECS: 203-474-9

4,5 % Glutaraldehyde  
Symbol: T,N  
R-phrase: 23/25-34-42/43-50  
EINECS: 203-856-5

1 - 5 % fatty alcohol ethoxylate  
Symbol: Xn  
R-phrase: 22-41  
EINECS: Polymer

5 -15 % Alkylbenzenesulfonate  
Symbol: Xi  
R-phrase: 38-41  
EINECS: 270-115-0

Material Safety Data Sheet according to 91/155/EEC - ISO 11014-1

Incidur

---

### 3. Hazards identification of the product

-----

Xn Harmful  
R 37/38: Irritating to respiratory system and skin  
R 41: Risk of serious damage to eyes  
R 42/43: May cause sensitization by inhalation and skin contact  
R 68/20/22: Harmful: possible risk of irreversible effects through inhalation and if swallowed.

### 4. First aid measures

-----

after inhalation:  
Fresh air, consult doctor if complaint persist.

after skin contact:  
Rinse with running water and soap. Skin care. Remove contaminated clothes.

after eye contact:  
Immediately flush eyes with copious amounts of running water (for 10 minutes), see an oculist.

after ingestion:  
Rinse out mouth, drink 1-2 glasses of water, seek medical advice.

### 5. Fire-fighting measures

-----

Suitable extinguishing media:  
suitable for all regular extinguishing materials

Extinguishing media which must not be used for safety reasons:  
none known

Special exposure hazards arising from the product itself, from combustion products or from resulting gases:  
none known

Special protective equipment for firefighters:  
Wear self-contained breathing apparatus.

### 6. Accidental release measures

-----

Personal precautions:  
Avoid contact with skin and eyes.  
Ensure adequate ventilation.

Material Safety Data Sheet according to 91/155/EEC - ISO 11014-1

Incidur

---

Environmental precautions:

Do not allow large amounts to be released into the sewer system.

Methods of cleaning up/of removing:

Remove mechanically wash away residue with plenty of water;

Other indications:

Dilute small quantities with large amount of water and rinse.

7. Handling and storage

-----

Handling:

no special measures required

Storage:

Store only in the original container.  
Do not store at temperatures above 25°C;

Storage Class: VCI-storage class: 10 (BRD)

8. Exposure controls / personal protection

-----

Information on the system design:

No special measures required

Components with specific control parameters:

The product contains glutaraldehyde, CAS-No.: 111-30-8. The relevant German exposure-limit for working place (MAK-value) according to 'TRGS 900' for this substance is 0,1 ppm = 0,4 mg/m<sup>3</sup>. (STEL-category =1=)  
May be harmful if maximum allowable concentration (MAK) is exceeded.

Personal protection:

wash off any dirt that gets onto the skin with lots of soap and water, skin care;  
The German accident prevention regulations (UVV) for health service and welfare (BGW BGV C8 and GUV 8.1 the BUK) specify in their Art. 7 the protective clothing to be worn for cleaning and disinfection measures.

Respiratory protection: when processing large amounts

Hand protection: Wear Category III (EN 374) chemical protective gloves made of butyl rubber or nitrile rubber. Please observe the glove manufacturer's instructions on permeability and rupture times as well as the specific workplace conditions.

Eye protection: goggles which can be tightly sealed

Material Safety Data Sheet according to 91/155/EEC - ISO 11014-1

Incidur

---

#### 9. Physical and chemical properties

-----

Physical state: liquid  
Colour: green  
Odour: aldehyde-like

pH: (undiluted) (20°C) ca. 4,5

Cloudpoint: < 0 °C  
Clarification point: > 0 °C

Flash point: aqueous preparation

Relative density: (20°C) 1,09 g/cm<sup>3</sup>

Solubility: (20°C) soluble in water

Viscosity: (20°C) ca. 15 mPa.s Höppler

#### 10. Stability and reactivity

-----

Conditions to avoid:  
No decomposition if used according to specifications

Materials to avoid:  
none known if used for its intended purpose

Hazardous decomposition products:  
none if used for intended purpose none known

#### 11. Toxicological information

-----

Possible risks of irreversible effects.

Inhalation:  
Harmful by inhalation  
Irritating to respiratory system

Ingestion:  
Harmful if swallowed

Skin contact:  
The product is irritant to skin and mucous membranes.

May cause sensitization by inhalation. May cause sensitization by skin contact

Eye contact:  
Risk of serious damage to eyes

Material Safety Data Sheet according to 91/155/EEC - ISO 11014-1

Incidur

---

#### 12. Ecological information

-----

Persistence and degradability:

This product contains surfactants which are at least 90 % biodegradable by reference to the German regulation June 4, 1986.

#### 13. Disposal considerations

-----

Use rest of contents as far as possible according to instructions.

The valid EWC waste code numbers are source-related. The manufacturer is therefore unable to specify EWC waste codes for the articles or products used in the various sectors.

In case of doubt we will be happy to advise you.

Can be added to materials collection after completely emptying.

#### 14. Transport information

-----

Not a hazardous material according to RID/ADR, GGVS/GGVE, ADN, IMDG, ICAO-TI/IATA-DGR.

#### 15. Regulatory information

-----

Classification and labelling according to GefStoffV:

Symbols of danger:

Xn Harmful

Ingredients:

Glutaral (Glutaraldehyd), Glyoxal

R-phrases:

R 37/38: Irritating to respiratory system and skin

R 41: Risk of serious damage to eyes

R 42/43: May cause sensitization by inhalation and skin contact

R 68/20/22: Harmful, possible risk of irreversible effects through inhalation and if swallowed.



Material Safety Data Sheet according to 91/155/EEC - ISO 11014-1

Incidur

---

S-phrases:

S 2: Keep out of reach of children  
S 23: Do not breathe spray  
S 26: In case of contact with eyes, rinse immediately with plenty of water and seek medical advice  
S 36/37/39: Wear suitable protective clothing, gloves and eye/face protection  
S 45: In case of accident or if you feel unwell, seek medical advice immediately (show the label where possible)

National prescriptions:

WGK = 2 water-endangering product (manufacturer classification in conformity with calculation method of the German VwVwS of May 17, 1999).

16. Other information

-----  
This information is based on our current level of knowledge and relates to the product in the state in which it is delivered. It is intended to describe our products from the point of view of safety requirements and is not intended to guarantee any particular properties.

Full text of the R-phrases indicated by codes in this safety data sheet. The product code/identification/designation is indicated in Section 15.

R 20: Harmful by inhalation.  
R 22: Harmful if swallowed  
R 23/25: Toxic by inhalation and if swallowed.  
R 34: Causes burns  
R 36/38: Irritating to eyes and skin.  
R 38: Irritating to skin  
R 41: Risk of serious damage to eyes  
R 42/43: May cause sensitization by inhalation and skin contact.  
R 43: May cause sensitization by skin contact.  
R 50/53: Very toxic to aquatic organisms, may cause long-term adverse effects in the aquatic environment.  
R 68: Possible risks of irreversible effects

### Declaration of Decontamination / Return Declaration

Following declarations serve for keeping safety and health of our employees. Fill in the forms and attach them when returning freeze dryers, centrifuges, spare parts and accessories. Please understand that we cannot carry out any work before we have the declarations. (We recommend to make several copies of this page.)

!!!! Attention – This form must be glued on outside of the packing !!!!

### Return declaration

	YES	NO
Decontamination declaration inside :		
Unit / component contaminated :		
Unit / component unused (new) :		

!!!! Attention – This form must be glued on outside of the packing !!!!



Declaration of Contamination of Freeze Dryers, Vacuum-Concentrators, Centrifuges, Accessories and Vacuum Pumps

This declaration may only be filled in and signed by authorised staff.

Repair Order dtd. : \_\_\_\_\_
Order No. : \_\_\_\_\_
Type of unit : \_\_\_\_\_ Serial No. : \_\_\_\_\_
Type of unit : \_\_\_\_\_ Serial No. : \_\_\_\_\_
Type of unit : \_\_\_\_\_ Serial No. : \_\_\_\_\_
Type of unit : \_\_\_\_\_ Serial No. : \_\_\_\_\_
Accessories : \_\_\_\_\_

Is the equipment free from harmful substances ? YES [ ] NO [ ]

If not, which substances have come into contact with the equipment?

Name of the substances : \_\_\_\_\_

Remarks (e.g. to be touched with gloves only) : \_\_\_\_\_

General characteristics of the substances :

- Corrosive [ ] Explosive [ ]
Biologically hazardous [ ] Radioactive [ ]
Toxic [ ]

In combination with which substances may hazardous mixtures develop?

Name of the substances : \_\_\_\_\_

Has the equipment been cleaned before shipment? YES [ ] NO [ ]

Is the equipment decontaminated and not harmful to health? YES [ ] NO [ ]

Prior to repair, radioactively contaminated components must be decontaminated according to the valid regulations for radiation protection.

Legally Binding Declaration

I / we hereby declare that the information on this declaration are correct and complete.

Company / Institute : \_\_\_\_\_
Street : \_\_\_\_\_
Postcode, City : \_\_\_\_\_
Tel. : \_\_\_\_\_ FAX : \_\_\_\_\_
Name : \_\_\_\_\_

Date : \_\_\_\_\_ Stamp : \_\_\_\_\_

Signature : \_\_\_\_\_

Table with 4 columns: Formblatt Unbedenklichkeitserklärung, Unbedenk.doc, Erstellt: Dieckmann, Genehmigt: Dr. Seeringer, Datum: 13.07.99, Rev.: 0 vom 13.07.1999



# 10. Special functions



